

Инструкция по эксплуатации

Камерная машина С300

MC06



**РЕМОНТ И
ОБСЛУЖИВАНИЕ
ВАКУУМНЫХ
УПАКОВЩИКОВ**

☎ 8 495 477 53 62
☎ 8 915 321 38 38

✉ info@2bw.ru
🌐 remvac.ru

Contents

Important information on the manual	7
Machine documentation	7
Changes not covered in the manual	8
Symbols used	8
Manual layout	9
1 Safety	10
1.1 General safety instructions	10
1.1.1 Target group	10
1.1.2 Unauthorised modifications and manufacture of spare parts	12
1.2 EC Conformity	13
1.3 Intended use	14
1.3.1 Electromagnetic compatibility (EMC)	14
1.3.2 Non-ionising radiation	14
1.4 Reasonably foreseeable incorrect use	14
1.5 Warning against incorrect use	15
1.6 Residual risks	15
1.7 Obligations of the operating company	15
1.7.1 Creating the operating directive	15
1.7.2 Monitoring obligation	16
1.7.3 Making the selection of personnel	16
1.7.4 Training the personnel	16
1.7.5 Providing personal protective equipment	17
1.7.6 Avoiding hazards	17
1.7.7 Providing the installation location	17
1.7.8 Providing the power supply	17
1.7.9 Observe the requirements for the gas supply	17
1.7.10 Avoiding hygiene risks	18
1.7.11 Checking the packs	19
1.7.12 Testing pressure equipment	20
1.8 Danger zones	20
1.8.1 Control cabinet	22
1.8.2 Vacuum pump	22
1.9 Safety devices	22
1.9.1 Main switch	24
1.9.2 Safety devices	25
1.10 Machine labels	25
1.10.1 Safety labels and information labels	26
2 Description	30
2.1 Design of the machine	30
2.1.1 Front view	30
2.1.2 Rear view	31

2.2	Control terminal.....	32
2.3	Optional equipment.....	34
2.3.1	Pouch clamp	34
2.3.2	Suction throttle	34
2.3.3	Holder for gas cylinder	35
2.4	Display	35
2.4.1	Startup display	35
2.4.2	Status display.....	36
2.4.3	Menu display	37
2.4.4	Function display	37
2.4.5	Diagnostic display	38
2.4.6	Access rights.....	38
2.5	Menu tree	39
2.6	Process sequence.....	39
2.7	Packaging process.....	40
2.8	Preset recipes	40
2.9	Technical specifications	41
3	Start-up.....	45
3.1	Checking the delivery.....	45
3.2	Initial start-up.....	45
3.2.1	Setting up the machine	45
3.2.2	Filling the vacuum pump with oil	47
3.3	Connecting the power supply.....	50
3.4	Attach the gas cylinder to the machine	51
3.5	Connecting inert gas	53
3.6	Cleaning the machine (basic cleaning)	53
4	Operation	54
4.1	Switching on the machine	54
4.2	Switching off the machine	54
4.3	Packing products.....	54
4.4	Opening and closing menus.....	57
4.4.1	Calling up menus	57
4.4.2	Quitting menus.....	57
4.5	Changing values	57
4.6	Selecting and resetting access rights.....	58
4.6.1	Selecting access authorisations.....	58
4.6.2	Resetting the access right to operator (blocking access).....	58
4.6.3	Change password for authorisation access creator	58
4.6.4	To reset authorisation access creator	58
4.7	Language selection	59
4.7.1	Selecting the language via menu	59
4.7.2	Selecting the language via the shortcut key.....	59
4.8	Working with recipes	59
4.8.1	Load recipe	59
4.8.2	Load factory settings.....	60
4.8.3	Save recipe	60

4.8.4	Delete recipe	60
4.9	Select and set process	61
4.9.1	Set standard process	61
4.9.2	To set MCV process	61
4.9.3	Setting the MHP process	62
4.9.4	Setting the MPP process	62
4.9.5	Set MRP process	63
4.10	Setting the sealing	63
4.11	Entering basic settings	64
4.12	Modifying and resetting machine cycles	64
4.13	Display production data	64
4.13.1	Display total cycles of the machine	64
4.13.2	Display hours of operation	65
4.13.3	Display cycle time	65
4.13.4	Show settings	65
4.14	Setting the brightness of the display	65
4.15	Reset machine control	66
4.16	Setting the suction speed	67
5	Adjustment work and setup	68
5.1	Setting the pressure regulators	68
5.1.1	Setting the operating pressure for sealing	68
5.2	Insert and remove the sloping insert	69
6	Cleaning	70
6.1	Notes on cleaning	70
6.1.1	Rules of conduct	70
6.1.2	Creating a company cleaning directive	70
6.1.3	Measures for ensuring a long service life	70
6.1.4	Parameters for pre-rinsing and after-rinsing water	71
6.1.5	Handling cleansers	71
6.1.6	Use with disinfectant	72
6.1.7	Corrosion protection and lubrication	73
6.1.8	Cleaning devices	73
6.2	Cleaning the machine	74
6.2.1	Cleaning procedure	74
6.2.2	Perform intermediate disinfection	76
6.2.3	Performing daily cleaning	76
6.2.4	Performing intensive cleaning	82
6.3	Care products table	89
7	Maintenance	91
7.1	Maintenance schedule	91
7.2	Maintenance recommendation	92
7.2.1	Entire machine - Visual inspection	92
7.2.2	Entire machine - Perform intermediate disinfection	93
7.2.3	Entire machine - Alkaline cleaning and disinfection	93
7.2.4	Entire machine - Perform a wipe test	93

7.2.5	Entire machine - Acidic cleaning and disinfection	93
7.2.6	Entire machine - Intensive cleaning	93
7.2.7	Chamber lid viewing window - Visual inspection.....	93
7.2.8	Chamber lid gasket - Visual inspection	93
7.2.9	Sealing bars - Visual inspection	94
7.2.10	Connections - Visual inspection	94
7.2.11	Internal vacuum pump - Checking oil level, topping up.....	94
7.2.12	External vacuum pump - Checking oil level, topping up	94
7.2.13	Internal vacuum pump - Visual inspection	95
7.2.14	External vacuum pump - Visual inspection	95
7.2.15	Vacuum pump type MRP60 - Oil change.....	96
7.2.16	Vacuum pump type MRP60 - Exchanging the air de-oiling element.....	96
7.2.17	Vacuum pump type R5-RAxxx - Changing the oil and oil filter	96
7.2.18	Vacuum pump type R5-RAxxx - Exchanging the air de-oiling element.....	96
7.2.19	Vacuum sensor - Exchanging the filter	96
7.2.20	Basic setting - Checking, adjusting	96
7.2.21	Vacuum system - Check	96
7.2.22	Vacuum filter (option) - Change	96
7.2.23	Entire machine - Check the age.....	97
7.3	Change the oil in the vacuum pump MRP60.....	98
7.3.1	Drain oil	98
7.3.2	Add oil to the vacuum pump.....	99
7.4	Change the air de-oiling element MRP60	100
7.5	Performing the vacuum test	103
7.6	Exchanging the vacuum sensor filter	104
7.7	Replace the sealing bar	104
7.7.1	Remove the sealing bar	104
7.7.2	Install the sealing bar	105
7.8	Lubricant table.....	106
8	Troubleshooting	107
8.1	Faults with diagnostic message	107
8.2	Faults without diagnostic message	109
9	Shutdown, transport, storage	111
9.1	Shutting down the machine.....	111
9.1.1	Cleaning the machine	111
9.1.2	Closing and disconnecting supply lines	111
9.1.3	Preserving the machine	111
9.2	Transporting the machine	111
9.2.1	Transporting the machine	111
9.2.2	Preparing the machine for onward transport (i.e by truck).....	113
9.3	Storing the machine	114
10	Disposal	116
10.1	Disposing of the machine.....	116
10.2	Dispose of operating materials.....	116
10.2.1	Disposing of oil and grease.....	116

10.2.2 Disposing of packaging materials	117
10.2.3 Dispose of chemicals	117
11 Spare parts.....	119
Glossary	123
Index	133
MULTIVAC branch offices.....	137

Important information on the manual

Read the manual carefully before you begin working with the machine.

- This manual is an integral component of the unit. Keep the manual for future reference.
- Do not work with the machine until you have read through the manual and completely understood its contents.
- Please contact MULTIVAC as soon as possible if there is something you do not understand in the manual! Your comments will help us to further improve the manual.
- Do not start up the machine if there are any visible defects!
- Only trained persons are permitted to install, operate and service the machine. The operating company is responsible for the qualifications and training of operating personnel.
- If you sell, transfer ownership or lend the machine to others, you must provide the manual along with it!

For reasons of clarity, some illustrations show the machine without the prescribed safety devices. Operating the machine without the safety devices is prohibited.



Injury hazard!

Altered, damaged, defective or incorrectly applied or missing safety devices will render the danger zones unprotected.

Unprotected danger zones can cause serious or even fatal injuries.

- Do NOT alter the safety devices.
- Use only MULTIVAC spare parts and accessories.

Before switching on the machine each time:

- Check that all safety guards close completely and prevent reaching into the danger zones.
- Check that only those safety devices are used which are suitable for the machine equipment.
- Check that all safety devices are functional and in a technically flawless condition.

Machine documentation

- Instruction manual.
- Electrical circuit diagram and pneumatic diagram.
- EU Declaration of Conformity
- Supplementary sheet "Super-PIN" (loose page enclosed with the machine).



Info

The complete scope of delivery is listed in the order confirmation.

Changes not covered in the manual

Continuous development is the foundation for ensuring that our machines are technically advanced and of high quality. For this reason, you may discover slight deviations between the specifications in the manual and your machine. We also cannot rule out errors. The specifications, figures and descriptions in this manual do not constitute a legal contract between the manufacturer and customer.

Symbols used

Warnings draw your attention to hazards. Warnings are displayed in the following form:



Danger from electrical shock!

Used to indicate that serious danger of electrical shock is imminent. Ignoring this danger can cause serious or even fatal injuries.

- Observe the notices for avoiding danger.



Immediate danger!

Used to indicate that serious danger is imminent. Ignoring this danger can cause serious or even fatal injuries.

- Observe the notices for avoiding danger.



Dangerous situations!

Used to indicate dangerous situations. Non-observance can cause serious or even fatal injuries.

- Observe the notices for avoiding danger.



Potentially dangerous situations!

Used to indicate potentially dangerous situations. Ignoring this danger can cause injuries.

- Observe the notices for avoiding danger.

NOTICE

Danger of material damage!

Used to indicate potentially dangerous situations. Ignoring these situations can cause material damage.

- Observe the notices for avoiding danger.

Information that contributes to a better understanding of how the machine functions is shown in the following form:



Info

Indicates information on special features deserving your attention.

Instructions to follow are displayed in the following form:

➤ Press key A.

➤ Release screw B.

➤ Press key C.

- Enumerated items are marked with bullet points.
 - Dashes are used to mark sub-items of enumerated lists or sequences of steps to be taken.

Manual layout

- Chapter 1 "Safety":
Generally valid safety instructions are to be observed.
- Chapter 2 "Description":
Description of the main assemblies, functions in the display and technical data.
- Chapter 3 "Start-up":
Notes on starting up and making connections.
- Chapter 4 "Operation":
Information on using the machine.
- Chapter 5 "Adjustment work and setup":
Notes regarding adjustment and setup.
- Chapter 6 "Cleaning":
Instructions for cleaning and information on care products.
- Chapter 7 "Maintenance":
Maintenance table and instructions for maintenance.
- Chapter 8 "Troubleshooting":
Contains information on how to recognise the causes of malfunctions and troubleshoot them.
- Chapter 9 "Shutdown, transport, storage":
Instructions for shutting down, transporting and storing the machine.
- Chapter 10 "Disposal":
Notes regarding disposal of the machine.
- Chapter 11 "Spare parts":
Machine wearing parts and spare parts.

1 Safety

1.1 General safety instructions

The machine incorporates the latest technological principles. Nevertheless, potential hazards for persons, the machine and other materials cannot be entirely excluded.

- Before you start up the machine, read through the instruction manual and follow the instructions contained therein.
- Keep the instruction manual near the machine for future reference.
- Observe the safety and accident prevention regulations valid in your country.

1.1.1 Target group

The persons, who work with or at the machine, must have as a minimum requirement the following capabilities, knowledge and competence:

- The persons are authorized by the company operating the machine to carry out those tasks, which they perform with or at the machine.
- The persons are at least 14 years old.
- The persons know the danger zones of the machine and the accident prevention regulations.
- The persons know how they should behave in an emergency situation.
- The persons have been given instruction about the machine and are familiar with the handling of it.
- The persons have read and understood the operating directive.
- The persons have read and understood the instruction manual of the machine.
- The persons have been informed about the possible hygiene risks.

The persons, who put the machine into service, or adjust and set it up, or who are responsible for maintenance work and eliminating faults, must have the following capabilities, knowledge and competence:

- Due to their professional training, knowledge and experience, as well as their familiarity with the relevant regulations, the persons are able to assess the tasks assigned to them and to recognize potential hazards.
- The persons can read and interpret technical texts and technical drawings or plans.
- The persons are familiar with the handling of computer-controlled machines.
- The persons can install components and modules for technically complex systems.

- The persons can ensure that the machine remains capable of operation.
- The persons can perform maintenance work and inspections.

The persons, who carry out work on electrical components, must have as a minimum requirement the following capabilities, knowledge and competence:

- Due to their professional training, knowledge and experience, as well as their familiarity with the relevant regulations, the persons are able to assess the tasks assigned to them and to recognize potential hazards.
- The persons have been trained as qualified electricians and are able to prove this.
- The persons have up-to-date knowledge and experience in the electrical area, and they have actively practised these skills in recent years.

The persons, who carry out work on gas supplies, must have as a minimum requirement the following capabilities, knowledge and competence:

- Due to their professional training, knowledge and experience, as well as their familiarity with the relevant regulations, the persons are able to assess the tasks assigned to them and to recognize potential hazards.
- The persons have been trained in handling gas supplies and are able to prove this.
- The persons have up-to-date knowledge and experience in gas supplies, and they have actively practised these skills in recent years.



Injury hazard!

Operating the machine in a negligent and inattentive manner is very dangerous.

Negligent handling, inattentiveness and a disorderly work area can cause serious injuries.

- Do NOT operate the machine if you are tired or under the influence of alcohol or medication.
 - Work attentively and with care.
 - Wear personal protective equipment.
 - Keep the work area clean and orderly.
 - Only carry out work for which training has been given.
-

NOTICE **Danger of material damage!**

Improper use of the machine can damage it. Damage can cause faults in the machine, which in turn can result in reject packs.

- Do NOT overload the machine.
- Clean and service the machine on a regular basis.
- Check if the machine is in full working order prior to starting work.
- Do NOT start the machine if you notice defects, damage or a change in the operating behaviour of the machine.
- Have faults and damage repaired immediately by an authorised technician.
- Repairs and service work should only be carried out by an authorised technician.

1.1.2 Unauthorised modifications and manufacture of spare parts

Genuine MULTIVAC spare parts and accessories provide the highest level of safety for personnel. Parts and equipment from other manufacturers have not been tested by MULTIVAC and are therefore not approved. The use of such components can alter the properties of the machine and thereby impair safe operation.



Injury hazard!

It is very dangerous to use third-party parts. The use of third-party parts endangers safe operation and can cause serious injuries.

- Do NOT perform any unauthorised modifications or conversions.
- Do NOT modify or remove any protective or safety devices.
- Use only MULTIVAC spare parts and accessories.

The manufacturer disclaims any liability for damage caused by the use of third-party parts or unauthorised modifications.



**Choose the Original
Choose Success!**

Fig. 1: Pro Original

The lubricants recommended by MULTIVAC are ideally matched to the individual modules of the machine.

NOTICE **Danger of material damage!**

The use of unsuitable lubricants can increase the wear of the machine and lead to corrosion of the transport chains.
This can damage the machine.

- Only use recommended lubricants for the transport chains.

1.2 EC Conformity

In the design and construction of packaging lines, packaging machines or auxiliary equipment for packaging machines, the following regulations have been observed:

- EC Machinery Directive 2006/42/EC.
- EC Electromagnetic Compatibility Directive 2004/108/EEC (exception: industrial trucks such as lifting trolleys and die changing trolleys).
- Regulation 1935/2004/EC on materials and articles intended to come into contact with food.

The safety objectives of the EC Low Voltage Directive 2006/95/EC are complied with in accordance with point 1.5.1 of Annex I to the EC Machinery Directive 2006/42/EC (exception: industrial trucks such as lifting trolleys and die changing trolleys).

Agent authorised to compile the relevant technical documentation according to Directive 2006/42/EC:

MULTIVAC Sepp Hagenmüller GmbH & Co. KG
Department of Technical Services
Bahnhofstraße 4
87787 Wolfertschwenden, Germany

Manufacturer:

MULTIVAC Sepp Hagenmüller GmbH & Co. KG
Bahnhofstraße 4
87787 Wolfertschwenden, Germany

Managing Director:

H.-J. Boekstegers

Agent authorised to compile the relevant technical documentation according to Directive 2006/42/EC:

MULTIVAC Packaging Systems España, S.L.
Avda. Sot de les Vernedes, 22-26
E-08396 Sant Cebrià de Vallalta

Manufacturer:

MULTIVAC Packaging Systems España, S.L.
Avda. Sot de les Vernedes, 22-26
E-08396 Sant Cebrià de Vallalta

Plant Manager:

Txus Baquero

1.3 Intended use

The machine is a piece of technical equipment to be used exclusively as a working appliance. The machine may only be operated by persons older than 14 years of age.

Use the machine only to pack products in pre-made film pouches.

The film pouches are closed with a seal seam.

For specifications, see Technical specifications.

Any other use is considered improper and can endanger persons, the product and the machine.

1.3.1 Electromagnetic compatibility (EMC)

The machine has been designed for use in residential, business and industrial areas (without a separate power substation, it can be connected directly to the public mains). Operation can be impaired when used in an industrial environment.

1.3.2 Non-ionising radiation

The machine produces unintended non-ionising radiation. This is only emitted by electrical operating equipment as a function of its inherent technical nature. e.g. from electric motors, high voltage wires, magnetic coils. There are moreover no strong permanent magnets built into the machine. Any effect on active implants can therefore be excluded with a high degree of probability as long as a safety distance of 30 cm is maintained between the implant and the field source. Active implants can be: heart pacemakers, defibrillators etc.

1.4 Reasonably foreseeable incorrect use

The following work methods are not in accordance with regulations and therefore are prohibited:

- Operation in an atmosphere capable of explosion.
- Packing of highly flammable, combustible or explosion-prone products.
- Packing of dust-forming or powder-forming material.
- Gas flushing of film pouches with explosive gas mixtures (e.g. oxygen proportion over 21 %).

- Use of the chamber lid and the viewing window in the chamber lid as a storage, working or cutting surface.
- Cleaning of the chamber lid and the viewing window in the chamber lid with cleaning agents which have an abrasive effect (e.g. abrasive household liquid cleaner, scouring pads, steel wool etc).
- Aseptic packing of products.



Info

Misuse will exclude any liability on behalf of the manufacturer. In such a case, the operating company alone bears the risk.

1.5 Warning against incorrect use

- Incorrect operation
For example: sealing times that are too short or too long and therefore result in improperly sealed packs which in turn damage the product.
- Neglecting the following work tasks:
 - Inspections.
 - Cleaning work.
 - Maintenance work.
- Use of third-party parts, i.e. parts that are not MULTIVAC spare parts.
- Operation under prohibited ambient conditions.

1.6 Residual risks

The safety instructions in this manual serve as guidelines for trained operating personnel in safe working practice with the machine. The manufacturer cannot however foresee all possible product-related hazards. This is why the safety instructions and warnings on the machine and in this manual cannot be considered exhaustive. The operating company and operating personnel remain ultimately responsible for safety.

1.7 Obligations of the operating company

1.7.1 Creating the operating directive

The machine and operating materials are a potential source of hazards. The operating company is obliged to draw up an operating directive. The operating directive regulates the handling of hazardous machines or operating materials, as well as laying down rules for behaviour in the case of an emergency. The required information can be found in the following documents:

- The EC directives for worker protection.
- National legislation.
- Accident prevention regulations.

- The machine instruction manual.

1.7.2 Monitoring obligation

The operating company is obliged to continuously monitor the condition of the entire machine, for example:

- Visible defects or damage.
- Changes in the operating behaviour.
- Age of the machine.

The operating company is obliged to ensure, that the machine is no longer operated when it is older than 19 years. The correct functioning of the safety functions for the electronic components can no longer be guaranteed after this age. The year of manufacture on the type plate of the machine serves as the starting point for assessing the age. In order to be able to operate the machine after this, the operating company must commission the manufacturer to check the safety functions of the machine.



Info

Do NOT start up the machine, if there are visible defects or if the machine is older than 19 years.

1.7.3 Making the selection of personnel

The operating company has to choose the personnel according to the tasks to be carried out, see Section 1.1.1 "TARGET GROUP". The operating company has to order and authorise the personnel for the tasks to be carried out.



Info

Trainees or other persons receiving instructions may only operate the unit under the constant supervision of an experienced technician.

1.7.4 Training the personnel

The operating company is responsible for ensuring, that the personnel is trained and instructed in accordance with the tasks, which have been assigned to them. The following measures can for example contribute to the training and instruction:

- Provide an operating directive, which is comprehensible to the personnel.
- Instruct personnel on how to handle the machine correctly.
- Make the machine instruction manual accessible to the personnel. If necessary, order an instruction manual from the manufacturer in the appropriate official language.
- Inform the personnel about measures for avoiding hygiene risks.
- MULTIVAC offers appropriate training courses.

1.7.5 Providing personal protective equipment

The operating company must ensure that the operators wear the required personal protective equipment (foot protection, head gear, gloves, etc.) in accordance with the national directives which apply. In Europe the directive 89/656/EEC specifies the minimum mandatory requirements for the use of personal protective equipment.

1.7.6 Avoiding hazards

The operating company must check, whether there are special hazards during operation, e.g. through hazardous fumes. The operating company must undertake measures to avoid or limit the hazards.

1.7.7 Providing the installation location

The operating company is obliged to provide a suitable installation location for the machine. The requirements for the installation location can be obtained from the manufacturer.

1.7.8 Providing the power supply

The power supply must be equipped as follows:

- Overcurrent protective device in accordance with IEC 60204-1: 2005
- Mains power breaker in accordance with IEC 60204-1: 2005.

Connection via residual current protective device

If the machine is to be operated via a residual current protective device, then a residual current protective device, which is sensitive to all types of current, should be used.



Info

In exceptional cases, the leakage current can be so high that an isolating transformer needs to be installed between the power supply and the machine.

Connection to IT network

The machine can not be connected directly to an IT network. The IT network must be converted to a TN-S network by an isolating transformer. The machine is connected to the TN-S network.

1.7.9 Observe the requirements for the gas supply



Info

Compliance with the following requirements is mandatory and is one of the operating company's imperative obligations!

General requirements

- The operating company is obliged to connect the gas supply in a way that poses no danger to employees or third parties.
- The operating company is obliged to create an instruction manual with all safety-related information for the following phases in the service life of the machine:
 - Starting up.
 - Operation and conduct in the event of unusual occurrences.
 - Servicing during operation.
 - Shutdown.
 - Rectification of faults.
- All parts of the gas supply and its equipment, which come into contact with oxidizing acting gases, are to be kept free of oil and grease.
- The operating company must ensure that the input and operating pressures given in the Technical specifications are adhered to and not exceeded.

Personnel qualifications

Only qualified persons with the corresponding required training, experience and reliability may perform work on the gas supply.

Structural requirements

- The operating company is obliged to install a pressure reducer and safety valve in the gas supply line to the machine.
- The operating company is obliged to connect the machine to the gas supply with a lockable ball valve.
When the ball valve is closed, the supply of gas to the machine is interrupted.
- It must be ensured that the input pressure at the machine does not exceed that given in the Technical specifications, e.g. through the fitting of an overpressure valve.
- The pressure relief capacity of the safety valve must be dimensioned for the maximum possible throughput of the pressure reducer.
- In the case of a release of pressure, the gas must be diverted to non-hazardous areas.

1.7.10 Avoiding hygiene risks

A high standard of hygiene is achieved through design, choice of materials and workmanship.

It is imperative that this high level of hygiene be maintained by every operating company. Particularly where food or sterile medical products are being packed, the currently valid hygiene standards must be strictly observed. The person charged by the operating company with safety and/or hygiene must clarify, which regulations apply to the

product to be packed, and the person must then implement these regulations.

The manufacturer assumes no liability whatsoever for any warranty claims and damage claims of any kind resulting from insufficient hygiene and insufficient cleaning.



Health hazard!

Insufficient or sporadic cleaning can promote the growth of micro-organisms which can change unfavourably the product that is to be packed.

This can severely damage the health of people, especially of the consumers.

Among other measures the following are definitely required:

- Create a company cleaning guideline.
 - Perform cleaning regularly.
 - Check the effectiveness of cleaning procedures on a regular basis.
 - Follow instructions in the chapter 'Cleaning'.
-

1.7.11 Checking the packs

**Health hazard!**

Faulty or damaged packs (reject packs) can have far-reaching consequences, for example, spoiled products.

Spoiled products can pose a health hazard.

- Check packs on a regular basis during running operation.
 - Do NOT put faulty or damaged packs (reject packs) into circulation.
-

**Info**

It is the operating company's duty to determine the overall testing procedure.

Testing procedure

Depending on the film pouch and the demands placed on the packs, various types of testing procedures are available, e.g.:

- Check seal seam width.
- Visual inspection: Asses the pack optically.
- Storage test: Store a good pack for a defined period and then re-inspect.
- Stacking test: Stack good packs on top of each other for a defined period and then re-inspect.
- Check the seal seam strength with a tensile testing machine.
- Low-pressure test (for vacuum packs).
- Measurement residual oxygen (for gas-flushed packs).

The following faults can result in a pack not being airtight:

- A leaky seal seam. Possible reasons:
 - The inside of the packaging material is contaminated by product in the seal seam area.
 - The sealing time is too short.
- Damage to the pack caused e.g. by sharp-edged products.

Time of inspection

- After machine start-up.
- When a defined time interval was reached during running operation.
- When the pack size was changed.
- When other types of films or other film thicknesses are being used.
- When spare parts or wearing parts were built in.
- After faults to the machine were eliminated.
- After changes to the machine settings.

1.7.12 Testing pressure equipment

The operating company is responsible for observing the country-specific test intervals for pressure equipment. This test is to be performed by qualified persons.

1.8 Danger zones

Be particularly aware of the following danger zones:

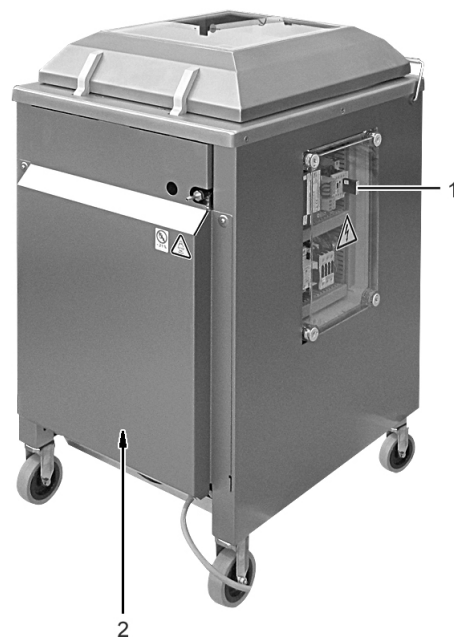

Fig. 2: Danger zones

- 1 Control cabinet
- 2 Vacuum pump



Injury hazard!

Altered, damaged, defective or incorrectly applied or missing safety devices will render the danger zones unprotected.

Unprotected danger zones can cause serious or even fatal injuries.

- Do NOT alter the safety devices.
- Use only MULTIVAC spare parts and accessories.
Before switching on the machine each time:
 - Check that all safety guards close completely and prevent reaching into the danger zones.
 - Check that only those safety devices are used which are suitable for the machine equipment.
 - Check that all safety devices are functional and in a technically flawless condition.

1.8.1 Control cabinet



Dangerous voltage!

The control cabinet contains electrically charged components. Various components are still under a dangerous voltage even after the machine has been switched off.

Touching electrically charged components can cause serious or even fatal injuries.

- Only qualified electricians are permitted to work on electrically charged components.
- Do NOT touch damaged cables but have them replaced immediately by a qualified electrician.

Before beginning any work on electrically charged components:

- Switch off the main switch and attach a lock to prevent unauthorised start-up.
- Disconnect the machine's power supply from the mains electricity.

1.8.2 Vacuum pump



Burn hazard!

The surface of the vacuum pump can reach temperatures of over 70 °C during operation.

Touching the vacuum pump can lead to burns.

Before performing any work on the vacuum pump:

- Allow the vacuum pump to cool down.
- Wear personal protective equipment.

1.9 Safety devices

Safety devices on the machine:

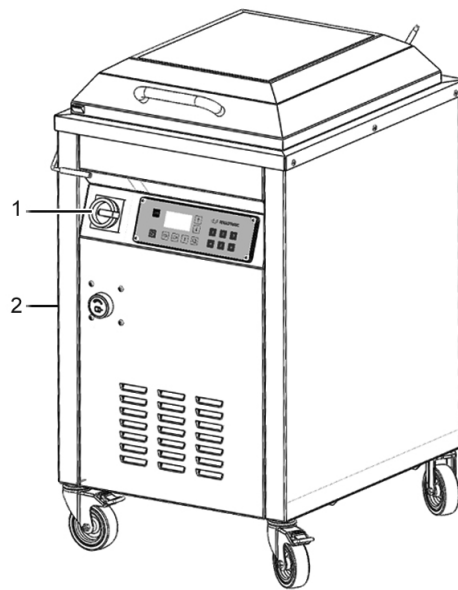

Fig. 3: Safety devices, front view

- 1 Main switch (option)
- 2 Protective device



Fig. 4: Safety devices, rear view

- 1 Protective device



Injury hazard!

Altered, damaged, defective or incorrectly applied or missing safety devices will render the danger zones unprotected. Unprotected danger zones can cause serious or even fatal injuries.

- Do NOT alter the safety devices.
- Use only MULTIVAC spare parts and accessories.
Before switching on the machine each time:
 - Check that all safety guards close completely and prevent reaching into the danger zones.
 - Check that only those safety devices are used which are suitable for the machine equipment.
 - Check that all safety devices are functional and in a technically flawless condition.

1.9.1 Main switch



Fig. 5: Main switch I / ON

Switching off the main switch has the following effects:

- The packaging procedure stops.
- The vacuum in the chamber is maintained.

Position	Function
I / ON	Machine switched on.
O / OFF	Machine is switched off.



Dangerous voltage!

Turning off the machine with the main switch does not rid it of electrical current.

Touching electrically charged components can cause serious or even fatal injuries.

- Only qualified electricians are permitted to work on electrically charged components.

Before beginning any work on electrically charged components:

- Switch off the main switch and attach a lock to prevent unauthorised start-up.
- Disconnect the machine's power supply from the mains electricity.

1.9.2 Safety devices

Safety devices cover the danger zones lying beneath them. Depending on the equipment of the machine, various safety devices are used, e.g. side panels, doors, protective plates, etc.



Injury hazard!

Missing protective devices result in unprotected danger zones.

Reaching into unprotected danger zones can lead to serious or even fatal injuries.

- Do NOT put the machine into operation without protective devices.
- Check that all protective devices are attached and in a technically flawless condition.
- Check that all protective devices are completely closed without gaps.

1.10 Machine labels

Safety and information labels have been attached to the machine.

- Do NOT remove these labels.
- Make sure all labels are intact and legible.
- If necessary, clean the labels with soap and water.
 - Do NOT clean the labels with solvents.
- Replace damaged, scratched or illegible labels with new ones.



Info



Labels can be obtained from the manufacturer.

1.10.1 Safety labels and information labels

Front view

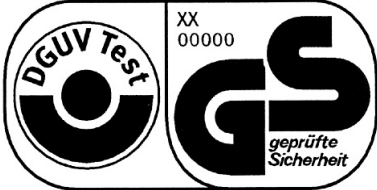

Fig. 6: Front view of the position of the labels

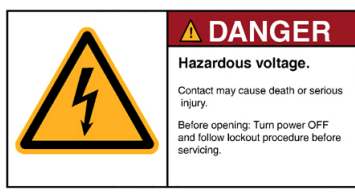
Position	Sign
1	 <p data-bbox="614 1406 794 1433">Fig. 7: GS mark</p>
2	<div style="display: flex; justify-content: space-around;"> <div data-bbox="614 1507 992 1720">  <p data-bbox="614 1691 992 1720">Fig. 8: ISO High voltage safety label</p> </div> <div data-bbox="1018 1507 1396 1720">  <p data-bbox="1018 1720 1396 1749">Fig. 9: ANSI High voltage safety label</p> </div> </div>

Position

Sign

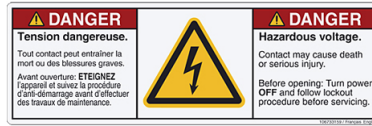

Fig. 10: ANSI High voltage safety label (English / French)

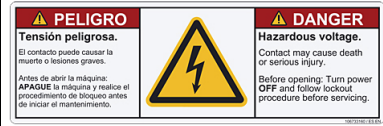

Fig. 11: ANSI High voltage safety label (English / Spanish)

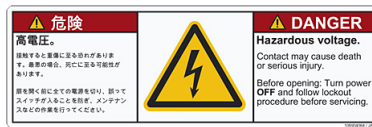

Fig. 12: ANSI high voltage safety label (English / Japanese)

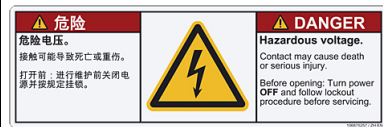

Fig. 13: ANSI High voltage safety label (English / Chinese)

3



Fig. 14: ISO mandatory sign: Read the instruction manual

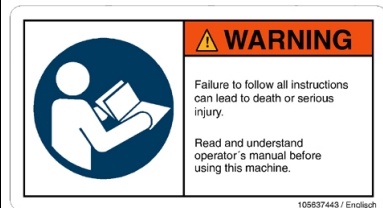

Fig. 15: ANSI mandatory sign: Read the instruction manual



Fig. 16: ANSI mandatory sign: Read the instruction manual (English / French)



Fig. 17: ANSI mandatory sign: Read the instruction manual (English / Spanish)

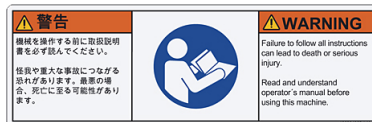

Fig. 18: ANSI mandatory sign: Read the instruction manual (English / Japanese)





Fig. 19: ANSI mandatory sign: Read the instruction manual (English / Chinese)

Rear view



Fig. 20: Rear view of the position of the labels

Position	Sign
1	 <p>Fig. 21: Type plate</p>
2	 <p>Fig. 22: Inert gas input pressure sign (option)</p>

Position	Sign
3	 <p>81.981.5118.30</p>

Fig. 23: Safety label on gas connection (option)

2 Description

2.1 Design of the machine

2.1.1 Front view

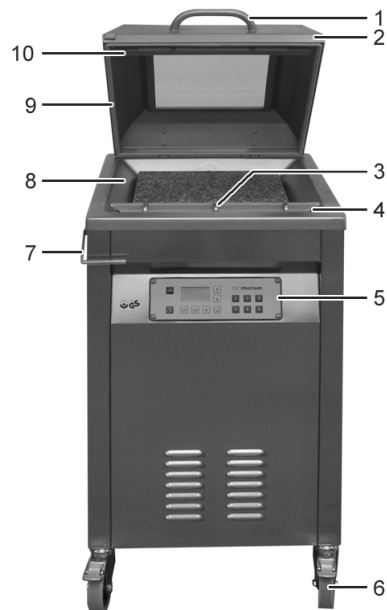

Fig. 24: Front view

- 1 Handle
- 2 Chamber lid
- 3 Inert gas nozzle (option)
- 4 Sealing bar
- 5 Control terminal
- 6 Swivel castor with parking brake
- 7 Locking device for chamber lid
- 8 Chamber
- 9 Chamber lid gasket
- 10 Counter-pressure bar or sealing bar (option)

2.1.2 Rear view



Fig. 25: Rear view

- 1 (Optional) Inert gas connection
- 2 Vacuum pump
- 3 Power supply

2.2 Control terminal

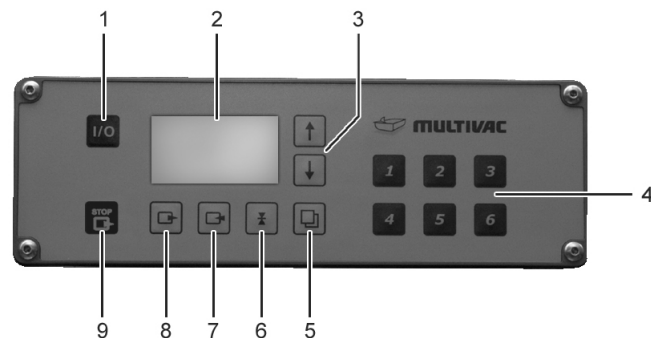











Fig. 26: Control terminal

- 1 <Machine control On/Off> key
- 2 Display
- 3 Keys <Arrow key>
- 4 Keys <1> to <6>
- 5 <Function selection> key
- 6 <Sealing> key
- 7 <Gas flushing> key
- 8 <Evacuation> key
- 9 <Stop> key

	<Machine control On/Off>	<ul style="list-style-type: none"> • Switch machine control on and off.
Display		<ul style="list-style-type: none"> • Display process data. • Show menus. • Show parameters and functions. • Graphic support. • Display diagnostic messages.
	<Arrow key>	<ul style="list-style-type: none"> • Increase values. • Navigation within menus.
	<Arrow key>	<ul style="list-style-type: none"> • Decrease values. • Navigation within menus.
	Keys <1> to <6>	<ul style="list-style-type: none"> • Load and save recipes. • Enter password. • Enter the configuration code.
	<Function selection>	<ul style="list-style-type: none"> • Call up additional menus. • Scroll to previous screen.

	<Sealing> key	<ul style="list-style-type: none"> • Press and hold down: Call up "Sealing" menu. • Press briefly: Call up values for sealing. • Confirm the configuration code. • In the MPP process: select the value.
	<Gas flushing> key	<ul style="list-style-type: none"> • In the MPP process: select the function. <p>In machines with the inert gas option:</p> <ul style="list-style-type: none"> • Press and hold down: Call up "Gas flushing" menu. • Press briefly: Call up values for gas flushing.
	<Evacuation> key	<ul style="list-style-type: none"> • Press and hold down: Call up "Evacuation" menu. • Press briefly: Call up values for evacuation. • Delete configuration code. • In the MPP process: select the step
	<Stop> key	<ul style="list-style-type: none"> • Skip current machine process and proceed with the next process. <ul style="list-style-type: none"> – Pressing during the evacuation process: Aborts the evacuation process and resumes the gas flushing process. – Pressing during the gas flushing process: Aborts the gas flushing process and resumes the sealing process. – Press during sealing process: Cancel sealing process and ventilate the chamber. • Acknowledge diagnostic message. • Return from the menu to the status display.

2.3 Optional equipment

2.3.1 Pouch clamp



Fig. 27: Pouch clamp

The pouch clamp fixes the film pouch in place during gas flushing.

2.3.2 Suction throttle

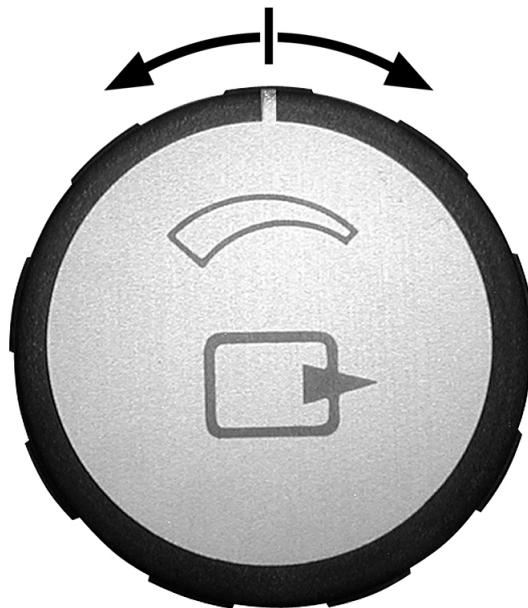

Fig. 28: Suction throttle

The suction throttle is used for the continuously adjustable setting of the suction speed when packing liquids.

2.3.3 Holder for gas cylinder



Fig. 29: Holder for gas cylinder

This holder attaches a gas cylinder to the machine.

The following gas cylinders can be attached to the machine:

- Max. diameter: 160 mm
- Max contents: 20 l

2.4 Display

The display shows different views with differing information depending on the machine's phase of operation.

2.4.1 Startup display

The startup screen appears after switching on the machine.

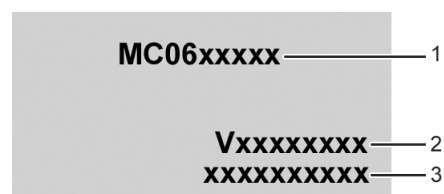

Fig. 30: Startup display

- 1 Type designation of machine control
- 2 Software version
- 3 Configuration code

2.4.2 Status display

Process data status display

The process data status display shows information on the last packaging procedure.

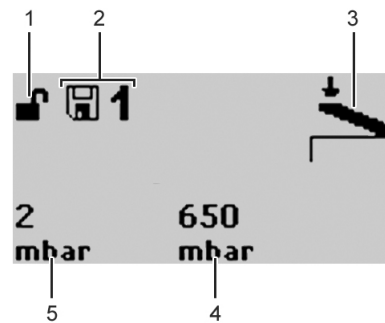

Fig. 31: Process data status display

- 1 Current access right (lock closed = user; lock open = set-up personnel)
- 2 Currently loaded recipe
- 3 Chamber lid symbol, machine is ready.
- 4 Gas pressure
- 5 Evacuation pressure

Process sequence status display

The process sequence status display shows the progress of the currently running process, e.g. evacuation. During the process the corresponding symbol flashes on the display. If time runs out during a process, then a clock with the remaining time will flash in place of the symbol.



Fig. 32: Evacuation status display (047)



Fig. 33: Gas flushing status display (049)



Fig. 34: Sealing status display (050)

2.4.3 Menu display

The menu display is a listing of the menus. The menu display can vary depending on the access right.

The arrow on the bottom right edge indicates a continued listing. Inactive menu options are shown with a dash (-).



Fig. 35: Example: Main menu (003)

2.4.4 Function display

Depending on the access rights, the function display will offer the following options:

- View values.
- Enter values.
- Switch functions on and off.

Example of a function display with values:

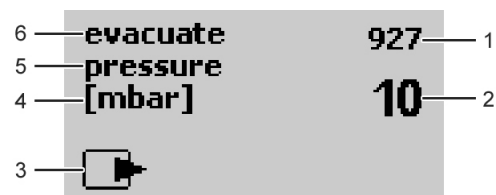

Fig. 36: Function display with value (052)

- 1 Actual value
- 2 Setting
- 3 Symbol of function (e.g. evacuation)
- 4 Measurement
- 5 Selected parameter
- 6 Selected function

Example of a function display for switching a function on and off:

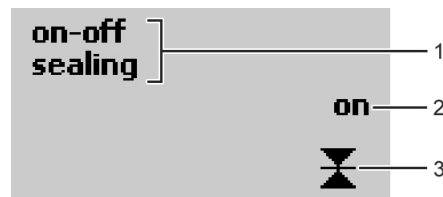

Fig. 37: Function display on/off (013)

- 1 Selected function
- 2 Switch status
- 3 Symbol of function (e.g. sealing)

2.4.5 Diagnostic display



Fig. 38: Diagnostic display

- 1 Diagnostic number
- 2 Type of error acknowledgement
- 3 Error text (in ticker)

Eliminate the malfunction, see Section 8 "TROUBLESHOOTING".

2.4.6 Access rights

To avoid incorrect operation, the following access rights are assigned.

Access right	Explanation
Operator	Not password protected. The operator may enter settings that are required to operate the machine (e.g. Language choice). The operator cannot modify values.
Set-up personnel	Password protected. The set-up personnel can modify values and switch statuses. Only a limited number of settings in the service menu are possible (e.g. vacuum test).
Service	Unrestricted authorisation.
Super-PIN	<ul style="list-style-type: none"> • Reset password for access right <i>Set-up personnel</i> to factory setting. • Reset machine control.

2.5 Menu tree

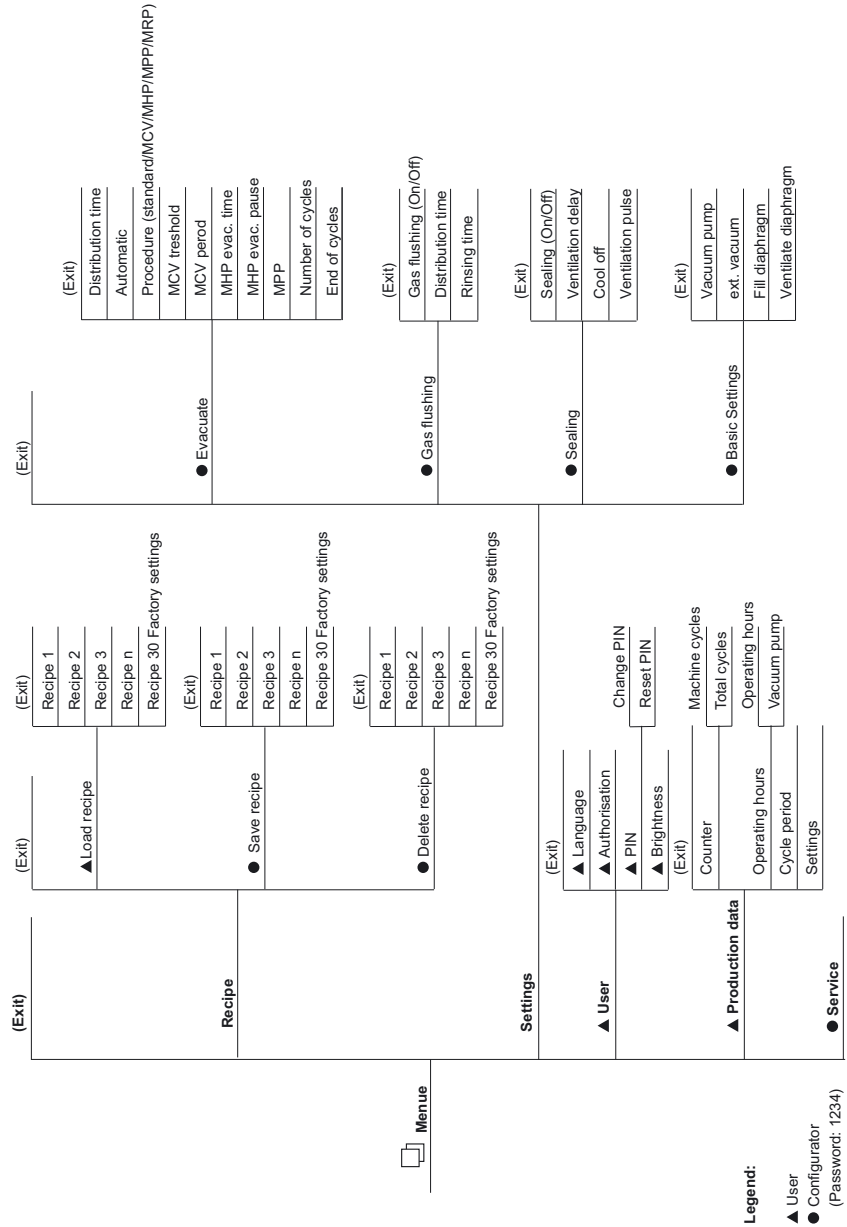

Fig. 39: Menu tree

2.6 Process sequence

The film pouches are filled and laid in the chamber. When the chamber is closed, the following procedures run automatically:



Evacuation

Evacuation if chamber and film pouches.



Gas flushing (optional)

Infeed of inert gas.



Sealing	<ul style="list-style-type: none"> Compressed air is admitted to the sealing diaphragm. The sealing diaphragm expands, pressing the sealing bar against the counter-pressure bar. The film pouch is sealed. The sealing bar and seal seam cool off. The sealing diaphragm is ventilated, the sealing diaphragm slackens. The chamber is ventilated. The chamber lid opens automatically if it is not locked.
---------	--

2.7 Packaging process

The following processes are available for packing products.

Processes	Example of use
Standard	Technical products or products without special requirements.
MCV	Testing airtightness of packs or for drying products.
MHP	Gentle evacuation of sensitive products with numerous air pockets.
MPP	Laboratory use.
MRP (Optional)	Reduction of residual oxygen content.

2.8 Preset recipes

Recipes 1 to 6 are preset at the factory. The settings depend on the machine equipment.



Info
Recipes 1 to 6 contain presettings which have to be adjusted to the individual cases.

Recipe	Example of use	Evacuation pressure	Automatic sensitivity	Gas flushing pressure	Sealing time	MHP
No. 1	For dry products without gas flushing.	Automatic	4	Off	1.8 s	Off

Recipe	Example of use	Evacuation pressure	Automatic sensitivity	Gas flushing pressure	Sealing time	MHP
No. 2	For moist products without gas flushing.	Automatic	10	Off	1.8 s	Off
No. 3	For dry products with little gas flushing.	Automatic	4	100 mbar to 150 mbar	1.8 s	Off
No. 4	For dry products with medium gas flushing.	Automatic	4	250 mbar	1.8 s	Off
No. 5	For dry products with strong gas flushing.	Automatic	4	500 mbar	1.8 s	Off
No. 6	For products with a big air pocket.	12 mbar	10	Off	1.8 s	Evacuation time: 2 s Evacuation pause: 4 s
No. 30	Factory settings	10 mbar	6	Off	1.3 s	Evacuation time: 2 s Evacuation pause: 2 s

2.9 Technical specifications

Power supply

Mains voltage	See type plate.
Phases	See type plate.
Nominal power	See type plate.
Nominal current	See type plate.
Maximum mains fuse	See type plate.
Maximum short-circuit current	See type plate.
Protection type	IP54

Dimensions

Height (a) with open chamber lid	1390 mm
Height (a) with closed chamber lid	1020 mm
Operating height approx.	900 mm
Width (b) without gas mixer	570 mm
Width (b) with gas mixer	720 mm
Depth (c)	695 mm
Effective chamber size (W/H/D)	440 mm/160 mm (optional 230 mm)/470 mm
Sealing length	440 mm
Weight approx.	160 kg

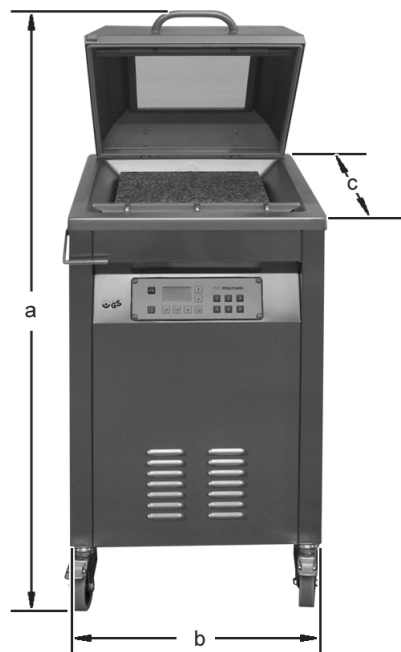

Fig. 40: Dimensions

Installation conditions and ambient conditions

Ambient temperature	+2 °C to +40 °C
Storage temperature	-25 °C to +80 °C
Relative air humidity during operation or storage of the machine, max.	90 % non-condensing
Inclination of the machine during transport, max.	15 °

Installation conditions and ambient conditions

Minimum room size for machines with the gas flushing option*	40 m ²
--	-------------------

*For safety reasons, a minimum room size is mandatory to prevent high concentrations of gas.

Inert gas without gas mixer (option)

Max. input pressure	2.5 bar
Min. input pressure	0.7 bar
Sealing operating pressure	1.0 bar
Inner diameter of supply line	8 mm

Inert gas with gas mixer (option)

Maximum CO ₂ input pressure	2.5 bar
Minimum CO ₂ input pressure	1.0 bar
Maximum N ₂ input pressure	3.5 bar
Minimum N ₂ input pressure	2.0 bar
Sealing operating pressure	1.0 bar
Inner diameter of supply line	6 mm

Vacuum pump

Nominal suction capacity R5-xxx	<ul style="list-style-type: none"> • 40 m³/h • 63 m³/h
Nominal suction capacity MRP60	<ul style="list-style-type: none"> • 50 Hz: 60 m³/h • 60 Hz: 75 m³/h
Achievable final pressure approx.	2 mbar

Noise exposure at the workplace

Based on	Machinery Directive (2006/42/EC)
Measuring instrument	Sound level meter, IEC 61672- 1, class 1, error limit +/-1.1 dB
Condition of the machine	New condition with optimum settings at the time of delivery.

Noise exposure at the workplace

A-weighted emission sound pressure level at the workplace
 L_{pA} (DIN EN ISO 11202, accuracy class 3)

≤ 70 dB

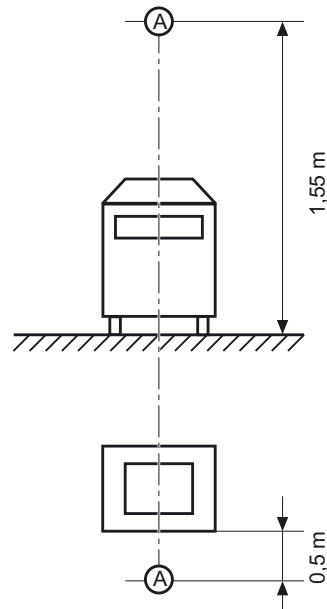

Fig. 41: Noise exposure measuring point



Info

The measured values of the noise emission values have been adjusted to take extraneous and ambient noises into account. Higher measured values may be produced as a result of the following:

- Highly sound-reflecting rooms.
- Modified settings.
- Wear.

3 Start-up

3.1 Checking the delivery

- Check the delivery for completeness and inspect for transport damage.
 - Inspect the crates.
 - Inspect the machine parts.
 - If transport damage is noted, immediately notify MULTIVAC service and report the damage.
 - Photograph the damage.
 - Have the photos sent to MULTIVAC service.
-

3.2 Initial start-up

3.2.1 Setting up the machine

**Info**

We recommend that a service engineer be requested for the machine installation.

- Prepare a firm, level site for the machine.
 - Ensure there is adequate access to the control cabinet and the connections at the desired location.
 - Wear personal protective equipment.
 - Remove packaging material.
 - Store the packaging material and accessories for later possible machine movements.
 - Remove the wooden blocks and boards for fixing the machine on the wooden base.
 - Use suitable and adequately sized load lifting equipment. Note here the machine dimensions and weight, see the shipping documents.
 - Set the forklift to the widest setting.
 - Position the load lifting equipment along the longer side of the machine.
 - While doing so establish the machine's centre of gravity. It can lie outside the centre point of the machine.
-

- Secure the machine on the load lifting equipment against tilting and falling over by using technically risk free transportation safety attachments.



Injury hazard!

Incorrect transport can cause the machine to fall or tip over. Standing in the danger zone can lead to serious injuries or even death.

- Do NOT stand under suspended loads.
- Lift the machine only at the designated points.
- Bear in mind the machine weight.

NOTICE Danger of material damage!

At an inclination of more than 15°, the oil in the vacuum pump shifts.

The air de-oiling elements will get wet from the oil and become ineffective. This will damage the vacuum pump.

- Transport and set the machine down as horizontally as possible.
- Do NOT tilt the machine.

- Lift the machine until the wooden base is free.
- Remove the wooden base below the machine.



Danger of explosion!

Operating the machine in a potentially explosive atmosphere can result in explosion due to hot machine parts.

Explosions can cause serious injuries or even death.

- Do NOT use the machine in rooms that are exposed to explosion hazards.
- Take into consideration the installation and environmental conditions at the location for the machine, see Technical Data.
- Transport the machine to the desired location.
- Set the machine down carefully.
- If the machine has swivel castors: Fix the machine in place by locking the swivel castors.

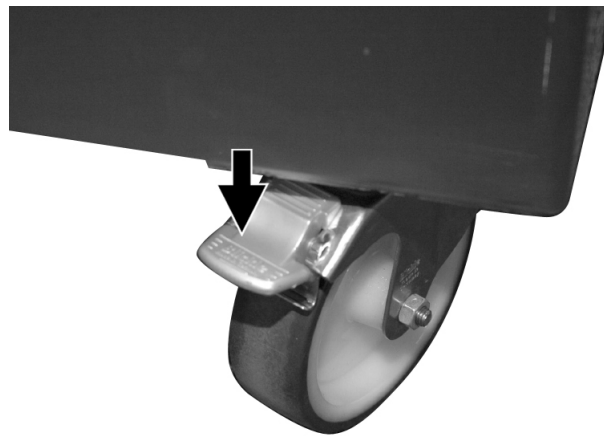

3.2.2 Filling the vacuum pump with oil.

Checking the oil level

-
- Switch off the machine.
-
- Disconnect the machine from the mains electricity.
-



Burn hazard!

The surface of the vacuum pump can reach temperatures of over 70 °C during operation.

Touching the vacuum pump can lead to burns.

Before performing any work on the vacuum pump:

- Allow the vacuum pump to cool down.
- Wear personal protective equipment.

-
- With an internal vacuum pump remove the safety guard.
-

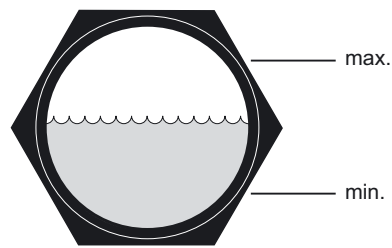

-
- Check the oil level on the oil sight glass.
 - The oil level should reach the middle of the oil sight glass.
 - If oil level is under the MIN mark, add oil.
-
- With an internal vacuum pump fasten the safety guard.
-

Adding oil

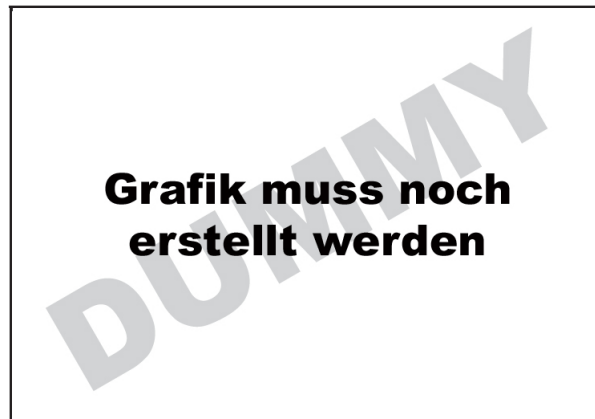

Fig. 42: Design of vacuum pump

- 1 Screw plug of fill opening
- 2 Oil sight glass
- 3 Screw plug of drain opening

-
- Switch off the machine.
-
- Disconnect the machine from the mains electricity.
-



Burn hazard!

The surface of the vacuum pump can reach temperatures of over 70 °C during operation.

Touching the vacuum pump can lead to burns.

Before performing any work on the vacuum pump:

- Allow the vacuum pump to cool down.
- Wear personal protective equipment.

➤ With an internal vacuum pump remove the safety guard.

➤ Unscrew the screw plug of the oil fill opening.

➤ Fill the vacuum pump with oil up to the middle of the oil sight glass. For lubricants, see the “Lubricant table”.

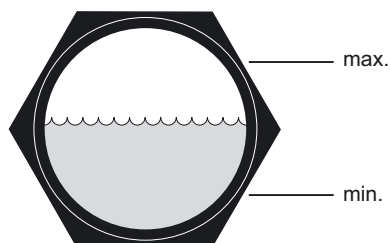

-
- Check the oil level on the oil sight glass:
 - The oil level should reach the middle of the oil sight glass.
 - If oil level is under the MIN mark, add oil.

➤ Replace the sealing ring in the screw plug.

➤ Insert the screw plug with the sealing ring in the fill opening and screw it tight.

-
- With an internal vacuum pump fasten the safety guard.
-
- Connect the machine to the mains electricity.
-
- Switch on the machine.
-
- Check the oil level after a couple of machine cycles.
-

3.3 Connecting the power supply

- If necessary, have the mains plug fitted and the power cable attached to the machine by a trained and qualified electrician, see electrical circuit diagram.
-
- Compare the voltage of the mains electricity with the mains voltage on the type plate.

NOTICE Danger of material damage!

If the mains voltage of the machine does not match that of the mains, the machine will be overloaded.
This can damage the vacuum pump.

- Connect the machine to the mains electricity only if the voltages are identical.
-
- If the values match, connect the machine to the mains electricity at a place which is always easily accessible.
 - When connecting an external vacuum pump or external auxiliary units, observe the electrical circuit diagram.
-

NOTICE Danger of material damage!

Interchanged phases on the electrical connection will cause the vacuum pump to rotate in the wrong direction.
Incorrect direction of rotation destroys the vacuum pump.

- Check the direction of rotation.
 - If the direction of rotation is not correct, switch off the machine immediately.
 - Have the phases interchanged by a qualified electrician.
-
- Check the direction of rotation of the vacuum pump.
 - Switch on the machine.

- Close and press down the chamber lid. Observe the pressure shown in the display.
 - Chamber lid is suctioned and the pressure falls: The vacuum pump is rotating in the correct direction.
 - Chamber lid is not suctioned within a maximum of 10 s and the pressure does not fall: The vacuum pump is rotating in the wrong direction.



Dangerous voltage!

The control cabinet contains electrically charged components. Various components are still under a dangerous voltage even after the machine has been switched off.

Touching electrically charged components can cause serious or even fatal injuries.

- Only qualified electricians are permitted to work on electrically charged components.
- Do NOT touch damaged cables but have them replaced immediately by a qualified electrician.

Before beginning any work on electrically charged components:

- Switch off the main switch and attach a lock to prevent unauthorised start-up.
- Disconnect the machine's power supply from the mains electricity.

- If the vacuum pump is rotating in the wrong direction, have the phases interchanged by a trained and qualified electrician.

3.4 Attach the gas cylinder to the machine



- Undo the chain on one side on the rear of the machine.

Start-up

Attach the gas cylinder to the machine

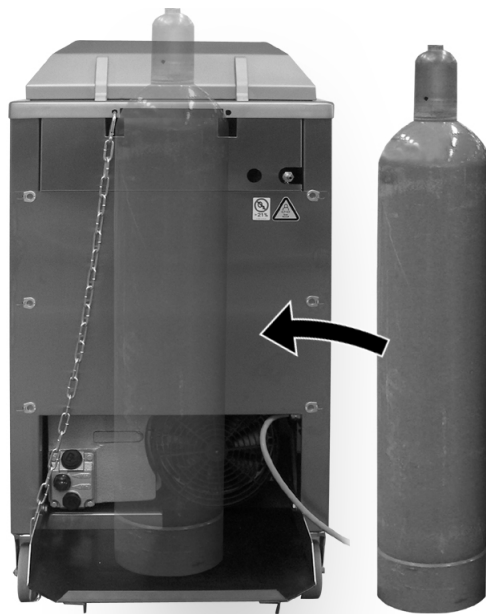

- Place the gas cylinder on the holder.
- Push the gas cylinder so that it touches the machine.
- Fasten the chain around the gas cylinder.
- Tension the chain so that the gas cylinder is well fastened.

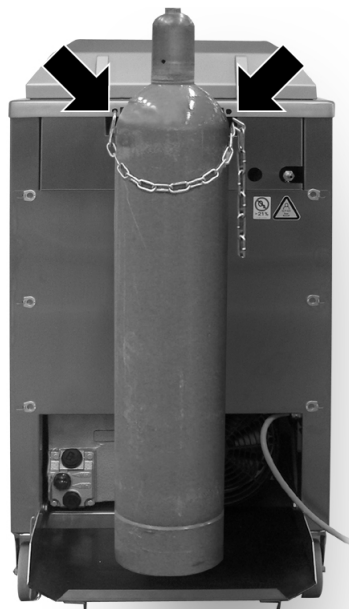

- Insert the chain.

3.5 Connecting inert gas



Danger of explosion!

Gas mixtures with oxygen proportions over 21% are explosive. A gas mixture with an oxygen proportion over 21 % can cause an explosion and fire if it comes in contact with heat, oil or grease.

- Do NOT use a gas mixture with an oxygen proportion of over 21%.



Risk of death!

During the packing process, inert gases are released. Inhaling inert gas can impair your breathing. Over a longer period of time, this can be fatal.

- A surface area of at least 40 square meters per machine must be made available.
- Ventilate the rooms sufficiently and avoid any accumulation of gas.
- Observe the maximum input pressure, see 'Technical specifications'.
- Cut off the gas supply at the end of work.
- Adhere to the safety regulations in effect in the country where the machine is used.



Info

Observe the minimum and maximum permitted input pressure, see "Technical specifications".

- Attach a stop-cock to the gas supply on the operating side.
- Attach the gas hose to the inert gas connection of the machine.
- Fasten the hose with hose clamps.
- Open the stop-cock for the gas supply.
- Set the input pressure; see the section technical specifications.

3.6 Cleaning the machine (basic cleaning)

- After putting the machine into service carry out an intensive cleaning of the machine, see Section 6 "CLEANING".



Info

The machine is only to be used for production after a basic cleaning.

4 Operation

4.1 Switching on the machine

- Open all stop valves in the supply lines.
 - If available, switch on the main switch.
 - Switch on the display with the <control on/off> key.
 - The machine control performs a self-test.
 - The software version of the machine control briefly appears in the display.
 - The status display appears.
 - The machine is ready for operation.
-

4.2 Switching off the machine

- Switch off the display with the <control on/off> key.
 - Turn off the main switch, if one is present.
 - Close all stop valves in the supply lines.
 - Close chamber lid and lock it in place.
 - If required disconnect the machine from the mains electricity.
-

4.3 Packing products

- Switch on the machine.
 - Load the desired recipe.
 - For the first test packs, use a preset recipe, see Section 2.8 "PRESET RECIPES " and see Section 4.8.2 "LOAD FACTORY SETTINGS ".
-



Health hazard!

Insufficient or sporadic cleaning can promote the growth of micro-organisms which can contaminate the product.

This can pose serious health hazards for consumers.

- Disinfect your hands should they come into contact with any machine part other than the operating elements.
 - Do NOT lay the product on the machine.
 - Observe the company cleaning guidelines.
 - Follow instructions in the chapter 'Cleaning'.
-

- Fill the film pouch.



- Insert film pouch.
 - The opening of the film pouch extends 2 to 3 cm beyond the sealing.

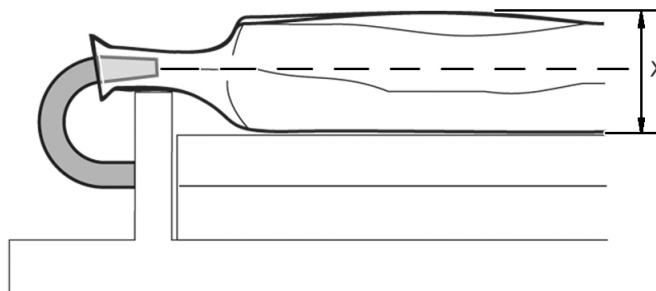

- If necessary, use filling plates.
 - The pouch neck should be located at the centre of the pouch height x.
- Use the sloping insert for packaging liquids, see Section 5.2 "INSERT AND REMOVE THE SLOPING INSERT".
 - Liquid cannot escape from the film pouch.

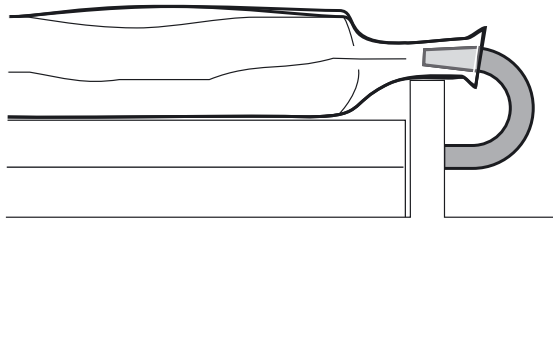

- Gas flushing option: Pull the pouch opening over the gas nozzles so that the inert gas flows into the film pouch.

- Pull the pouch neck flat on the sealing bar.
 - The pouch neck lies on the sealing bar without creases.
-



NOTICE Danger of material damage!

Penetration by foreign matter (e.g. liquids, product residue, foreign bodies) will damage the vacuum pump. Damage can cause faults in the machine, which in turn can result in reject packs.

- Cancel the evacuation process immediately if foreign matter is sucked in.
 - Change the oil in the vacuum pump.
-

- Close and press down the chamber lid.
 - The processes in the machine run automatically.
 - The chamber lid opens automatically if it is not locked.
-



- Remove the finished pack.
 - Check the pack.
-

**Info**

Visually inspect the packs on a regular basis while the machine is running. Depending on product and pack it may be necessary to carry out additional and considerably more complex test procedures. This is the responsibility of the operating company,.

-
- If necessary, adapt the settings to the product.
 - To adapt process, see Section 4.9 "SELECT AND SET PROCESS".
 - Enter all required times and values.
 - Save recipe, see Section 4.8.3 "SAVE RECIPE".
-

4.4 Opening and closing menus

4.4.1 Calling up menus

-
- Press the <function selection> key.
 - The "main menu" appears.
 - Select the desired menu with the <arrow> keys.
 - Press the <function selection> key.
 - The desired menu appears.
 - Select the desired submenu with the <arrow> keys.
 - Press the <function selection> key.
 - The desired submenu appears.
-

4.4.2 Quitting menus

-
- Using the <arrow> keys, select the respective menu heading.
 - The text of the menu heading changes and becomes the (menu) function *quit*.
 - Press the <function selection> key.
 - The menu is exited and the system changes to the next highest display level.
-

4.5 Changing values

-
- Call up the desired menu.
 - Using the <arrow> keys, select the desired parameter.
 - Press the <function selection> key.
 - The display for the selected parameter appears.
-

-
- Set the value with the <arrow> keys.
 - The set value is adopted.
 - To exit the parameter, press the <Function selection> key.
-

4.6 Selecting and resetting access rights

4.6.1 Selecting access authorisations

-
- Call up "User" menu.
 - Select *Authorisation*.
 - Enter the password with the keys <1> to <6>.
 - The corresponding access right appears in the status display.
 - If the selected access authorisation is no longer needed, reset the access to *operator*, see Section 4.6.2 "RESETTING THE ACCESS RIGHT TO OPERATOR (BLOCKING ACCESS)".
-

4.6.2 Resetting the access right to operator (blocking access)

-
- Call up "User" menu.
 - Select *Authorisation*.
 - Enter the password of the current access right with the keys <1> to <6>.
 - The *Operator* access right appears in the status display.
 - Settings cannot be changed.
-

4.6.3 Change password for authorisation access creator

-
- Call up "PIN" menu.
 - Select *Change PIN*.
 - Enter old password with keys <1> to <6>.
 - Enter new password with keys <1> to <6>.
 - Confirm the new password again.
 - The password has been changed.
 - The status display appears.
-

4.6.4 To reset authorisation access creator

-
- Call up "PIN" menu.

-
- Select *Reset PIN*.
-
- Enter Super-PIN, see supplementary sheet "Super-PIN".
 - The reset password for the authorisation access *Creator* appears.
 - The status display appears.
-

4.7 Language selection

4.7.1 Selecting the language via menu

-
- Call up "User" menu.
-
- Select *Language*.
-
- Using the <arrow> keys, select the desired language.
-
- Press the <Function selection> key.
 - The language is activated.
-

4.7.2 Selecting the language via the shortcut key

-
- Switch off the display with the <Machine control on/off> key.
-
- Switch on the display with the <Machine control on/off> key.
-
- While the startup display is shown, press the <Function selection> key.
 - The "language selection" display appears.
-
- Using the <arrow> keys, select the desired language.
-
- Press the <function selection> key.
 - The language is activated.
-

4.8 Working with recipes

4.8.1 Load recipe



Info

If no recipe is saved, the message "recipe missing" appears. The last settings remain active.

Load using keys <1> to <6>

-
- Press the desired key briefly <1> to <6>.
 - The selected recipe is loaded.
-

Loading through the “load recipe” menu

-
- Call up "Load recipe" menu.

 - Select the desired recipe with the <arrow> keys.

 - Press the <Function selection> key.
 - The selected recipe is loaded.
-

4.8.2 Load factory settings



Info

Factory settings cannot be overwritten or deleted.

-
- Call up "Recipe loading" menu.

 - Select recipe no. 30 with the <arrow> keys.

 - Press the <Function selection> key.
 - The factory settings are loaded.
-

4.8.3 Save recipe



Info

When selecting an already assigned recipe number, the recipe stored under this number is directly overwritten.

Saving via keys <1> to <6>

-
- Press and hold down desired key <1> to <6>.
 - The message "Recipe saved" appears.
 - The current values are stored in the selected recipe.
-

Saving via the “save recipe” menu

-
- Call up "Recipe, saving" menu.

 - Using the <arrow> keys, select the desired memory location.

 - Press the <Function selection> key.
 - The current values are stored in the selected recipe.
-

4.8.4 Delete recipe



Info

If the currently loaded recipe is deleted, a new recipe must be loaded.

-
- Call up "Recipe, deleting" menu.
-
- Select the recipe to be deleted with the <arrow> keys.
-
- Press the <Function selection> key.
 - The message "completed" appears.
 - The recipe has been deleted.
-

4.9 Select and set process

4.9.1 Set standard process

-
- Press <Evacuation> key briefly and enter value for *Evacuation pressure*.
 - For automatic evacuation, decrease the value until *Automatic* appears.
 - The machine controls the evacuation process automatically.
-
- Press <Evacuation> key briefly again and set value for *Post-evacuation time*.
-
- Call up the "evacuation" menu.
 - Set *Distribution time*.
 - Set *Automatic*.
 - Select *Standard* process.
-
- Call up the "gas flushing" menu (Optional).
 - Switch on *On/off gas flushing*.
 - Set *Distribution time*.
 - Set *Rinse time*.
-
- Press <Gas flushing> key briefly and set value for *Gas flushing pressure*.
-

4.9.2 To set MCV process

-
- Press <Evacuation> key briefly and enter value for *Evacuation pressure*.
-



Info

Do not set an *Evacuation pressure* value in *Automatic*.

-
- Press <Evacuation> key briefly again and set the value for *Post-evacuation time* to 0 s.
-
- Call up the "evacuation" menu.
 - Set the value for *Distribution time* to 0 s.
-

- Select *MCV* process.
- Set *MCV threshold*.
- Set *MCV duration*.

- Call up the "gas flushing" menu (Optional).

- Switch off *Gas flushing On/Off*.

- Call up the "sealing" menu.

- Switch off *Sealing On/Off*.

4.9.3 Setting the MHP process

- Press <Evacuation> key briefly and enter value for *Evacuation pressure*.
 - For automatic evacuation, decrease the value until *Automatic* appears.
 - The machine controls the evacuation process automatically.

- Press <Evacuation> key briefly again and set value for *Post-evacuation time*.

- Call up the "evacuation" menu.
 - Set *Distribution time*.
 - Set *Automatic*.
 - Select *MHP* process.
 - Set *MHP evacuation time*.
 - Set *MHP Evacuation pause*.

- Call up the "gas flushing" menu (Optional).
 - Switch on *On/off gas flushing*.
 - Set *Distribution time*.
 - Set *Rinse time*.

- Press <Gas flushing> key briefly and set value for *Gas flushing pressure*.

4.9.4 Setting the MPP process

- Call up the "gas flushing" menu.
 - Switch on *On/off gas flushing*.

- Call up the "evacuation" menu.
 - Select *MPP* process.

- Call up the *MPP* submenu.

- Select the desired function with the <Gas flushing> key and the <Arrow> keys.
 - Set the value with the <Sealing> key and the <Arrow> keys.
 - Scroll through the list using the <Evacuation> key and the <Arrow> keys.
-

4.9.5 Set MRP process

- Press <Evacuation> key briefly and enter value for *Evacuation pressure*.
 - For automatic evacuation, decrease the value until *Automatic* appears.
 - The machine controls the evacuation process automatically.
 - Press <Evacuation> key briefly again and set value for *Post-evacuation time*.
-
- Call up the "evacuation" menu.
 - Set *Distribution time*.
 - Set *Automatic*.
 - Select *MRP* process.
 - Set *Number of cycles*.
 - Set *Cycle end*.
-
- Call up the "gas flushing" menu (Optional).
 - Switch on *On/off gas flushing*.
 - Set *Distribution time*.
 - Set *Rinse time*.
-
- Press <Gas flushing> key briefly and set value for *Gas flushing pressure*.
-

4.10 Setting the sealing

- Call up the "settings" menu.
-
- Call up the "sealing" menu.
-
- Switch on *On/off sealing*.
-
- Set *Delayed ventilation*.
-
- Set *Cooling down*.
-
- Set *Ventilation pulse*.
-
- Press the <Sealing> key briefly and set the value for the first sealing time.

-
- Call up the "basic settings" menu.

 - Set *Fill diaphragm*.
 - Compressed air is admitted to the sealing diaphragm; this way the sealing bar is pressed against the counter-pressure bar.
 - If the chosen value is too low, the necessary sealing pressure is not reached and the seal seam can be unsatisfactory.

 - Set *Ventilate diaphragm*.
 - After the sealing and after the sealing time has elapsed, the sealing diaphragm is ventilated and thus slackened.
-

4.11 Entering basic settings

-
- Call up the "settings" menu.

 - Call up the "basic settings" menu.

 - Set the *vacuum pump running-on time*.

 - Set *Fill diaphragm*.

 - Set *Ventilate diaphragm*.
-

4.12 Modifying and resetting machine cycles

-
- Call up the "operating data" menu.

 - Call up "Counter" menu.

 - Call up *machine cycles*.

 - Set the value with the <arrow> keys or set to "0".
 - The set value is adopted.
-

4.13 Display production data

4.13.1 Display total cycles of the machine

-
- Call up the "operating data" menu.

 - Call up "Counter" menu.

 - Select *Total cycles*.
-

4.13.2 Display hours of operation

Display machine's hours of operation

-
- Call up the "Operating data" menu.

 - Call up "Hours of operation" menu.

 - *Select* Hours of operation.

Display vacuum pump's hours of operation

-
- Call up the "Operating data" menu.

 - Call up "Hours of operation" menu.

 - *Select Vacuum pump.*

4.13.3 Display cycle time

-
- Call up the "operating data" menu.

 - Select the "Cycle time" menu.
 - A list of cycle times is displayed.

4.13.4 Show settings

-
- To view the settings of recipes 7 through 30, load the desired recipe via the menu, see Section 4.8.1 "LOAD RECIPE".

 - Call up the "production data" menu.

 - *Select Settings.*
 - The settings of the loaded recipe appear in a list.



Info

The settings of recipes 1 through 6 can be speed dialed from the list. To do so, load the respective recipe with the keys <1> through <6>.

4.14 Setting the brightness of the display

-
- Call up "User" menu.

 - *Select brightness.*

 - Using the <arrow> keys set the desired brightness.

4.15 Reset machine control



Info

Reset machine control in the following situations:

- Creating the condition as supplied to the customer of the machine.
 - If the configuration code was incorrectly entered.
 - Delete the entire memory.
 - The machine control unit no longer responds.
-
- Displaying the configuration code.
 - Switch off the display with the <Machine control on/off> key.
 - Switch on the display with the <Machine control on/off> key.
 - Read off the set configuration code during the startup display and make a note of it.
-
- While the startup display is shown, press the keys <2> and <5> simultaneously.
-
- Enter Super-PIN, see supplementary sheet "Super-PIN".
 - The "Reset" display appears.
 - A counter counts to zero.
 - The display automatically switches off and back on again.
 - The password for the access right *Set-up personnel* remains activated.
 - The "Configuration code" display appears.
-
- Compare the suggested configuration code in the display with the noted configuration code.
-
- If the configuration codes match, press the <Sealing> key
 - The configuration code is saved.
-
- If the configuration codes differ, enter the noted configuration code.
 - Press the <Evacuation> key.
 - The suggested configuration code is deleted.
 - Enter the noted configuration code with the keys <1> to <6>.
 - Press the <Sealing> key.
 - The configuration code is saved.
-
- Switch off the display with the <Machine control on/off> key.
-
- Switch on the display with the <Machine control on/off> key.
 - Factory settings are loaded.
 - The status display appears.
-

4.16 Setting the suction speed

- Setting the suction speed on the suction throttle.
 - Turn the suction throttle anticlockwise.
 - The suction speed increases.
 - Turn the suction throttle clockwise.
 - The suction speed decreases.
-



Info

Determine the correct suction speed through trial and error.

5 Adjustment work and setup

5.1 Setting the pressure regulators

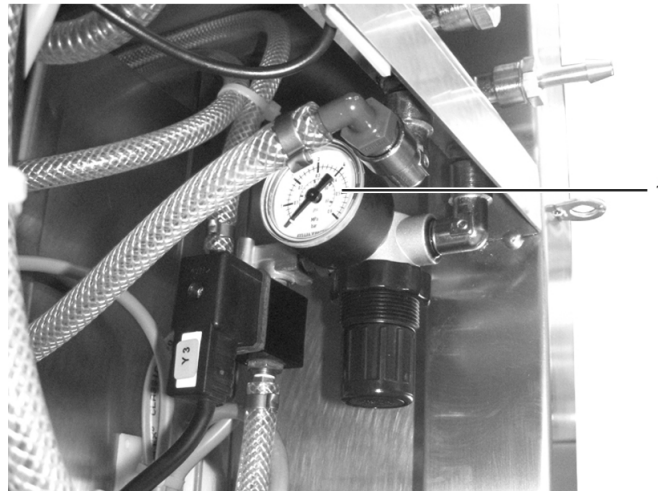

Fig. 43: Pressure regulator

1 Sealing pressure regulator

-
- Switch off the machine.

 - Disconnect the machine from the mains electricity.

 - Remove the safety guard on the back of the machine.

 - Set the operating pressure for sealing, see Section 5.1.1 "SETTING THE OPERATING PRESSURE FOR SEALING".

 - Fasten the safety guard.
-

5.1.1 Setting the operating pressure for sealing

-
- For setting the operating pressure on the "Sealing" pressure regulator, see "Technical specifications".

 - Turn the regulator clockwise.
 - The operating pressure is increased.

 - Turn the regulator anticlockwise.
 - The operating pressure is decreased.

 - Check the set operating pressure on the manometer.

 - If necessary, readjust the operating pressure.
-

5.2 Insert and remove the sloping insert

- If necessary, use filling plates for the desired incline.
- Hook the sloping insert on the screws of the sealing bar.

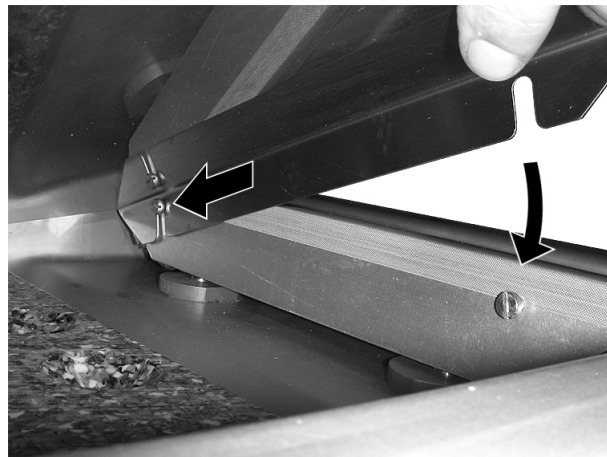

- Attach the support angle to the sloping insert at the required position.

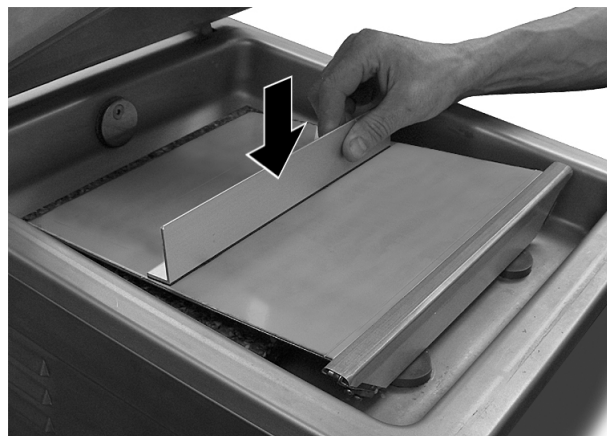

- If the sloping insert is no longer needed, remove it, along with the support angle, from the chamber.

6 Cleaning



Info

Observe the safety instructions, see Section 1 "SAFETY".
Clean the machine after maintenance work and repairs and disinfect if necessary.

6.1 Notes on cleaning

6.1.1 Rules of conduct

The objective of the cleaning work is to avoid risks to hygiene. If the cleaning is insufficient or not performed properly, this may result in the contamination of the products and to health hazards for end consumers. In addition, the machine may be damaged. Assign only properly instructed and qualified personnel. Information on qualification and training can be obtained from MULTIVAC Service.

The ability to handle materials effectively and efficiently depends on:

- Using the proper dosage of care products.
- Observing the application time of the care products.
- Proper temperature of the mixing water.

Data sheets for the care products can be obtained from their manufacturers. The manufacturers also provide information on the maximum permissible dosages which apply in the food area.

6.1.2 Creating a company cleaning directive

Specify the following points:

- Required cleaning intervals.
- Care products to be used. Care products, refer to "Care products table".
- Using the proper dosage of care products.
- Persons in charge of cleaning.
- First aid measures.

6.1.3 Measures for ensuring a long service life

NOTICE **Danger of material damage!**

Highly acidic or alkaline cleansers that contain chlorine create strong vapours.

These vapours cause corrosion.

- Do NOT use any care products that contain chlorine or are highly acidic or alkaline. Also, do NOT use such care products to clean the machine surroundings.
 - Observe the specifications of the care product manufacturers.
-

NOTICE Danger of material damage!

Acidic cleansers are caustic.

These can cause plastics to become brittle and age prematurely.

- Do NOT shorten the cleaning intervals for acidic cleaning and disinfection.

NOTICE Danger of material damage!

Inappropriate work on anodized aluminium parts causes a damaging of the anodized coating.

This will lead to aluminium corrosion.

- Do not use metal scraping tools.
- Do not use harsh cleansers.
- Do not use cleaning devices with abrasive surface.
- Residues of cleansers and other aggressive deposits must be removed immediately.

Regular and correct maintenance prolongs the life of the unit. The best protection against harmful influences is to clean and disinfect the machine on a regular basis. The longer product residue and other aggressive deposits remain on the unit, the more harmful their corrosive effects will be.

If used incorrectly, care products can damage components made of rubber or plastic. Before applying care products, please take time to read the notes and warnings provided by the manufacturer.

6.1.4 Parameters for pre-rinsing and after-rinsing water

- Low pressure of max. 4 bar to 6 bar (58 psi to 88 psi).
- Do not rinse with steam jets or high-pressure cleaners.
- Fan nozzle: 5 ° to 15 ° inclination, approx. 3/16 " nozzle opening.
- Temperature: max. 60 °C (140 °F).
- Quality of after-rinsing water: drinking water quality.

6.1.5 Handling cleansers

Chemical burn hazard!

Cleansers are caustic. Caustic effects are NOT noticed immediately.

Contact with the skin can cause burns.

- Wear the prescribed personal protective equipment when handling cleansers.
 - Observe the manufacturer's instructions.
-

- For type of cleander refer to the "Care products table".
- The quantity of cleanser is not the decisive factor for successful cleaning.
 - Applying amounts in excess of the proper dosage does not improve or accelerate cleaning efficiency, but only hinders the required rinsing off of the cleanser.
- Dried cleanser residues make cleaning more difficult and prolonged.
 - Even the smallest residues can inhibit the effect of the disinfection.
 - Check by measuring the pH factor of the post-rinsing water.
- Regular checks of cleaning (i.e. by contact tests) reduces the risk of product contamination.
- Insufficient cleaning cannot be compensated for by doubling the concentration of the disinfectants.

6.1.6 Use with disinfectant



Fire hazard!

Alcohol-based disinfectants are highly flammable. Fire, naked light or smoking ignites the disinfectant and can thus cause fires.

- When disinfecting the machine, flames or naked lights are prohibited.
- Smoking is prohibited.
- Observe the instructions of the disinfectant manufacturer.



Health hazard!

Incorrect use of disinfectant can contaminate the product with chemicals or decrease the effectiveness of disinfection. This can pose serious health hazards for consumers.

- Follow the instructions of the disinfectant manufacturer.
- Only rinse after disinfection if required by disinfectant manufacturer.
- Observe regional hygiene regulations.
- Create a company cleaning guideline.

- For type of disinfectant refer to the "Care products table".
 - For water-sensitive components only use alcohol-based disinfectant.
 - For all other components use disinfectants which are for example based on quaternary ammonium compounds.

6.1.7 Corrosion protection and lubrication

**Health hazard!**

Excess lubricants can accumulate at lubrication points.
Excess grease has no lubricating function; however, it can breed micro-organisms and contaminate the product.

- Check the lubricating points regularly for the accumulation of excess lubricants.
- Remove any excess lubricants.

NOTICE Danger of material damage!

Residues of cleansers and disinfectants produce corrosion.
Corrosion can destroy the machine.

- After every cleaning, including cleaning of the surroundings (floor, adjacent machines, etc.), thoroughly rinse with water of drinking water quality or clean by hand.

- Kind of anti-corrosion agent, refer to "Care products table".
- Only use H1 or FDA-approved lubricants and anti-corrosion agents.
- Checking the microbiological stability of the anti-corrosion agent and lubricants regularly helps reduce the risk of product contamination.

6.1.8 Cleaning devices

Wet cleaning

**Health hazard!**

The cleaning devices will become germ hot spots if they are not cleaned often enough.

This can cause cross contamination, which will damage the product.

- Use only plastic brushes and brooms.
- Clean the cleaning devices daily and apply disinfectant afterwards.

Dry cleaning

The exhaust air emitted by the vacuum cleaner and whirled up must comply with the prescribed limit values for the packaging environment. Accordingly, the appropriate filter elements must be used in the vacuum cleaner.

6.2 Cleaning the machine



Info

- The recommended daily cleaning tasks recommended here must be supplemented by the intensive cleaning procedure according to the degree of dirt.
- Cleaning personnel must be instructed for the cleaning work by the operating company.
- The sequence of the described tasks is to be followed exactly.

6.2.1 Cleaning procedure

The manufacturer recommends the following cleaning procedures:

- Low pressure cleaning
- Manual cleaning
- Low pressure disinfection
- Quick disinfection
- Dry cleaning.



Info

The procedure which is to be performed is noted in the respective step in the cleaning instructions.

Low pressure cleaning



Info

The company cleaning guidelines specify which cleanser (alkaline or acidic) is to be used.

-
- Perform the low-pressure foaming procedure to apply the cleanser.
-
- Wait until the contact time has elapsed (see instructions of cleanser manufacturer).
-
- If necessary, remove stubborn dirt and stains with a soft brush.
-
- Rinse off with water of drinking quality.
-
- Inspect for dirt and cleanser residues.
-
- If necessary, clean and rinse again.
-

Manual cleaning



Info

The company cleaning guidelines specify which cleanser (alkaline or acidic) is to be used.

-
- Perform manual cleaning with the cleaning solution and a soft cloth.
-
- Wait until the contact time has elapsed (see instructions of cleanser manufacturer).
-
- If necessary, remove stubborn dirt and stains with a soft brush.
-
- Wipe with new cloth and water of drinking quality.
-
- Inspect for dirt and cleanser residues.
-
- If necessary, perform another manual cleaning and wipe it off.
-

Low pressure disinfection

-
- Apply disinfectant with a hand-held spray lance.
-
- Wait until the contact time has elapsed (see instructions of disinfectant manufacturer).
-
- If necessary, rinse off with water of drinking quality; see instructions of the disinfectant manufacturer.
-

Quick disinfection

-
- Disinfect with alcohol-based disinfectant.
-
- Wait until the contact time has elapsed (see instructions of disinfectant manufacturer).
-

Dry cleaning

-
- Remove the dirt with a suitable vacuum cleaner.
-
- Remove the dirt from difficult to reach areas with a soft brush. Do not whirl up the dirt.
-
- Once again, remove the dirt with a suitable vacuum cleaner.
-
- Check for dirt residues.
-
- If necessary, clean it again.
-

6.2.2 Perform intermediate disinfection



Info

- Intermediate disinfection is a disinfection procedure during operation (e.g. after or immediately before short breaks) to reduce the growth of microorganisms. Quick disinfection is used for this.
- The sequence of the described tasks is to be followed exactly.
- In the following, optional equipment versions are also described. Only perform steps that correspond to the version of the machine.
- For all cleaning work, follow the safety instructions, see Section 6.1 "NOTES ON CLEANING".
- Performance of the respective cleaning procedure, see Section 6.2.1 "CLEANING PROCEDURE".

-
- Remove all products from the machine.
-
- Switch off the machine.
-
- Let the sealing bar cool down.
-
- Perform a quick disinfection of the following components: If there is visible contamination carry out a prior manual cleaning:
 - Handle on the chamber lid.
 - Locking device for chamber lid.
 - Chamber.
 - Control terminal.
-

6.2.3 Performing daily cleaning



Info

- The daily cleaning may only be performed by specially trained personnel, see Section 1.7.3 "MAKING THE SELECTION OF PERSONNEL".
- The sequence of the described tasks is to be followed exactly.
- In the following, optional equipment versions are also described. Only perform steps that correspond to the version of the machine.
- Always clean the machine from top to bottom.
- For all cleaning work, follow the safety instructions, see Section 6.1 "NOTES ON CLEANING".
- The illustrations are examples.
- Performance of the respective cleaning procedure, see Section 6.2.1 "CLEANING PROCEDURE".

Preparing for cleaning

-
- Remove all products from the machine.

-
- Switch off the machine.

 - Disconnect the machine from the mains electricity.

 - Cover the mains plug with waterproof plastic bags.

 - Close all stop-cocks in the supply lines.

 - Allow the machine and sealing bar to cool down.

 - Wrap up the empty new film pouches and store them outside of the room in a clean and dry place during the cleaning procedure.

 - Remove all waste (e.g. product scraps, film trim) on or around the machine.

 - Remove the following components:
 - Sloping insert with with support angle.
 - Filling plate.
 - Sealing bar.
-

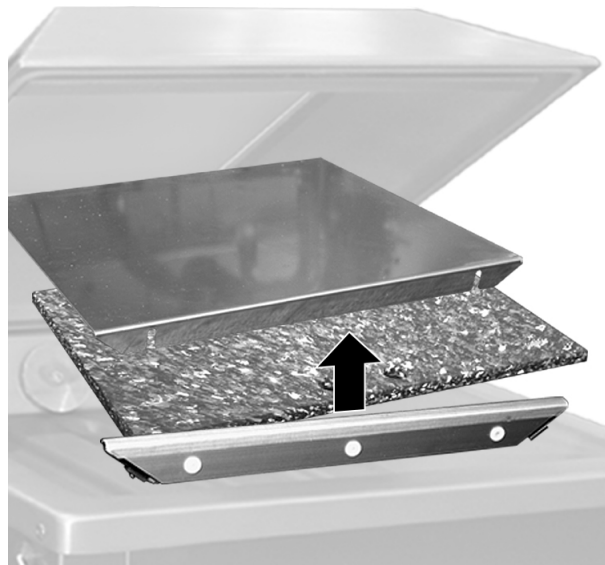

**Cleaning and
disinfecting the
removed components**

-
- Take the removed components to a separate room suitable for wet cleaning.
-

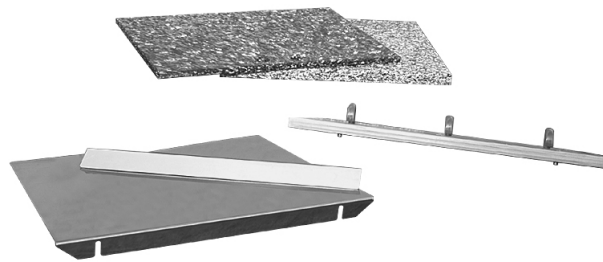

-
- NOTICE** **Danger of material damage!**
The Teflon tape of the sealing bar is very sensitive.
Improper cleaning can damage the Teflon tape.
- Clean the Teflon tape only with a soft cloth.
 - Do NOT scratch the Teflon tape.
-

- Manually clean the removed components.
 - Thoroughly clean the inert gas nozzles.
 - Perform a quick disinfection of the removed components.
 - Thoroughly disinfect the inert gas nozzles.
-

Disinfect and cover sensitive components

- If the external vacuum pump is connected directly to the mains electricity, have the external vacuum pump disconnected from the mains electricity by a qualified electrician.
 - Cover the mains plug with waterproof plastic bags.
-



- Burn hazard!**
The surface of the vacuum pump can reach temperatures of over 70 °C during operation.
Touching the vacuum pump can lead to burns.
Before performing any work on the vacuum pump:
- Allow the vacuum pump to cool down.
 - Wear personal protective equipment.
-

- Perform a quick disinfection of the following components: If there is visible contamination carry out a prior manual cleaning:
 - External vacuum pump.
 - Cover disinfected components with watertight film pouches.
-

Clean the machine and the floor

- Disassemble the liquid separator.
 - Remove the draining hose from the liquid separator.
 - Remove the compressed air hose.

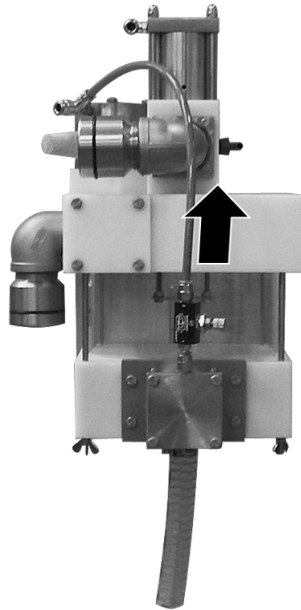

- Release the winged nuts and the retaining rings on the base of the liquid separator.

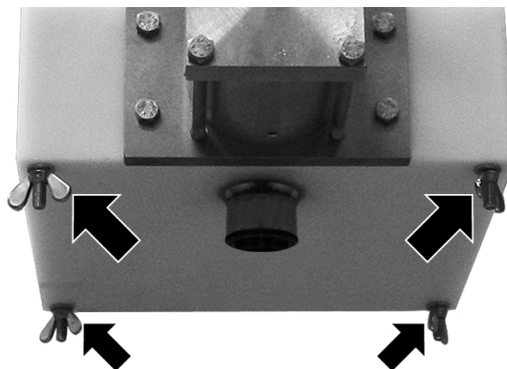

- Open the liquid separator.
 - Perform manual cleaning of the liquid separator.
 - Perform quick disinfection of the liquid separator.
 - Assemble the liquid separator.
-

NOTICE Danger of material damage!

Penetration by foreign matter (e.g. liquids, product residue, foreign bodies) will damage the vacuum pump.

Damage can cause faults in the machine, which in turn can result in reject packs.

- Do NOT spray directly on the covers of the suction openings in the chamber.

-
- Perform manual cleaning of the machine.

- Clean the viewing window in the chamber lid with a soft cloth or a soft brush.

-
- Close chamber lid and lock it in place.

-
- Clean the floor with a rubber wiper.

-
- Dispose of the dirty water and waste properly.

-
- Perform low pressure cleaning of the floor.

-
- Inspect the entire machine and the floor for dirt and cleanser residues.

-
- If necessary, clean and wipe off again.
-

**Disinfect the machine
and the floor**

-
- Perform low pressure disinfection of the floor.

-
- Open the chamber lid.

NOTICE Danger of material damage!

Penetration by foreign matter (e.g. liquids, product residue, foreign bodies) will damage the vacuum pump.

Damage can cause faults in the machine, which in turn can result in reject packs.

- Do NOT spray directly on the covers of the suction openings in the chamber.

-
- Perform quick disinfection of the machine.

-
- Leave the chamber lid open to dry.
-

Complete the cleaning

-
- Remove the plastic bag for protecting sensitive components.

-
- Remove the plastic bag from the mains plug.

-
- Dispose of plastic bags properly. For reasons of hygiene, never reuse bags.
-
- Attach or install the following components:
 - Sealing bar.
 - Filling plate.
 - Sloping insert with with support angle.
-

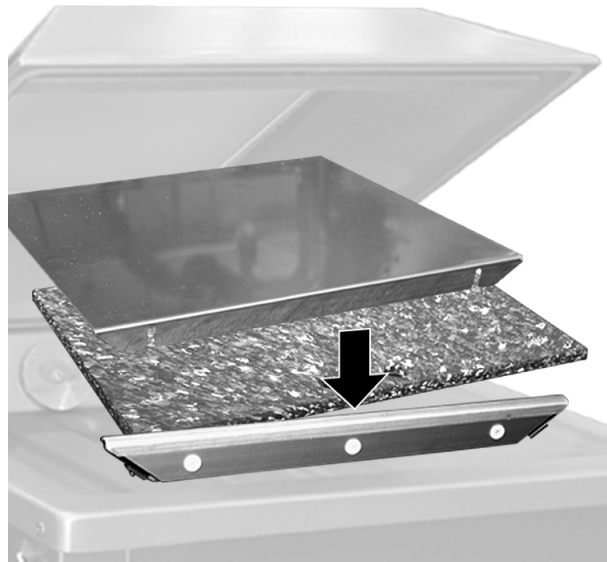

-
- Open all stop-cocks in the supply lines.
-
- Connect the machine to the mains electricity.
-
- If the external vacuum pump has its own power supply, have the external vacuum pump connected to the mains electricity by a qualified electrician.
-
- Perform quick disinfection of the whole loading area.
-
- Clean the cleaning devices (e.g. rubber wipers, brushes).
-
- Place cleaning devices in disinfectant solution.
-
- Unpack the film pouches and lay them ready.
-

6.2.4 Performing intensive cleaning



Info

- Intensive cleaning complements daily cleaning. As part of this process additional cleaning measures are required depending on the degree of contamination of the components described in this chapter.
- The intensive cleaning may only be performed by specially trained personnel. Information on qualifications and training can be obtained from our service personnel.
- The sequence of the described tasks is to be followed exactly.
- Always clean the machine from top to bottom.
- In the following, optional equipment versions are also described. Only perform steps that correspond to the version of the machine.
- For all cleaning work, follow the safety instructions, see Section 6.1 "NOTES ON CLEANING".
- The illustrations are examples.
- Performance of the respective cleaning procedure, see Section 6.2.1 "CLEANING PROCEDURE".

Preparing for cleaning

-
- Remove all products from the machine.
-
- Switch off the machine.
-
- Disconnect the machine from the mains electricity.
-
- Cover the mains plug with waterproof plastic bags.
-
- Close all stop-cocks in the supply lines.
-
- Allow the machine and sealing bar to cool down.
-
- Wrap up the empty new film pouches and store them outside of the room in a clean and dry place during the cleaning procedure.
-
- Remove all waste (e.g. product scraps, film trim) on or around the machine.
-
- Remove the following components:
 - Sloping insert with support angle.
 - Filling plate.
 - Sealing bar.
 - Chamber lid gasket.
-

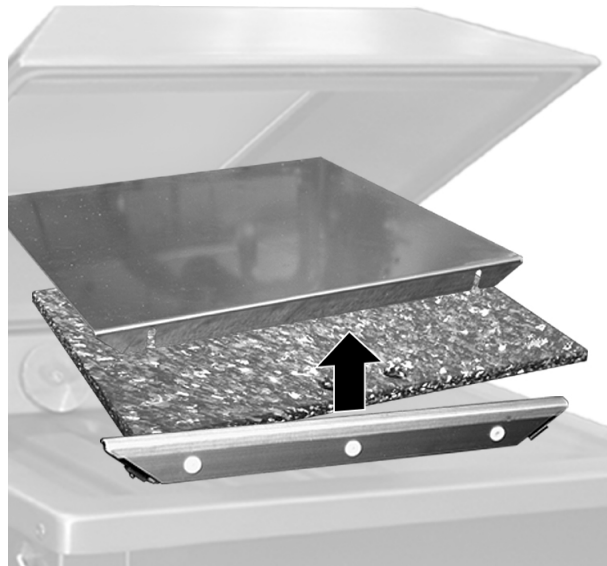

**Cleaning and
disinfecting the
removed components**

-
- Take the removed components to a separate room suitable for wet cleaning.
-

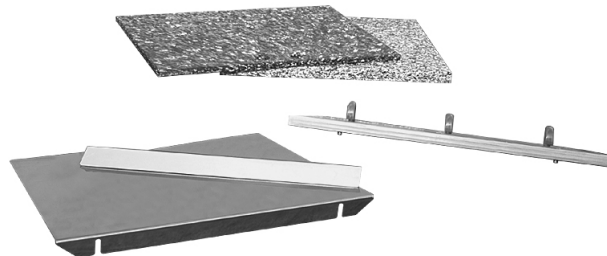

NOTICE Danger of material damage!
The Teflon tape of the sealing bar is very sensitive.
Improper cleaning can damage the Teflon tape.

- Clean the Teflon tape only with a soft cloth.
 - Do NOT scratch the Teflon tape.
-
- Manually clean the removed components.
 - Thoroughly clean the inert gas nozzles.
 - Perform a quick disinfection of the removed components.
 - Thoroughly disinfect the inert gas nozzles.
-

Disinfect and cover sensitive components

- If the external vacuum pump is connected directly to the mains electricity, have the external vacuum pump disconnected from the mains electricity by a qualified electrician.
 - Cover the mains plug with waterproof plastic bags.
-



Burn hazard!

The surface of the vacuum pump can reach temperatures of over 70 °C during operation.

Touching the vacuum pump can lead to burns.

Before performing any work on the vacuum pump:

- Allow the vacuum pump to cool down.
 - Wear personal protective equipment.
-

- Perform a quick disinfection of the following components: If there is visible contamination carry out a prior manual cleaning:
 - External vacuum pump.
 - Cover disinfected components with watertight film pouches.
-

Clean the machine and the floor

- Disassemble the liquid separator.
 - Remove the draining hose from the liquid separator.
 - Remove the compressed air hose.

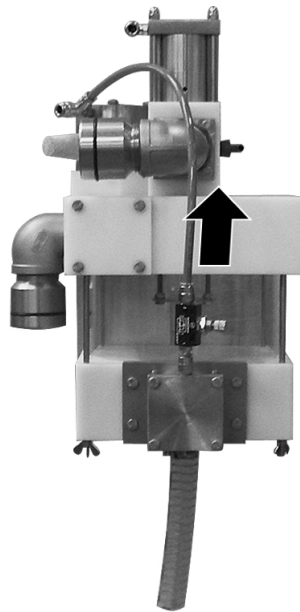

- Release the winged nuts and the retaining rings on the base of the liquid separator.

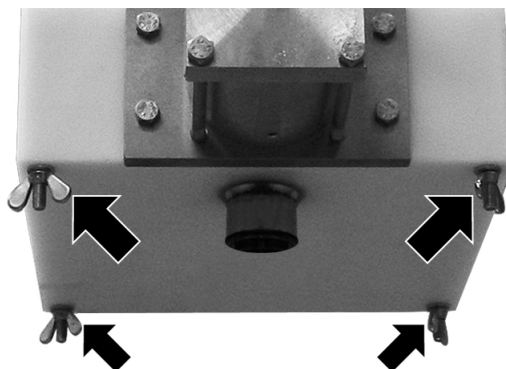

- Open the liquid separator.
- Perform manual cleaning of the liquid separator.
- Perform quick disinfection of the liquid separator.
- Assemble the liquid separator.

NOTICE **Danger of material damage!**

Penetration by foreign matter (e.g. liquids, product residue, foreign bodies) will damage the vacuum pump. Damage can cause faults in the machine, which in turn can result in reject packs.

- Do NOT spray directly on the covers of the suction openings in the chamber.

-
- Perform manual cleaning of the machine.

- Clean the viewing window in the chamber lid with a soft cloth or a soft brush.

- Close chamber lid and lock it in place.

- Clean the floor with a rubber wiper.

- Dispose of the dirty water and waste properly.

- Perform low pressure cleaning of the floor.

- Inspect the entire machine and the floor for dirt and cleanser residues.

- If necessary, clean and wipe off again.



Burn hazard!

The surface of the vacuum pump can reach temperatures of over 70 °C during operation.

Touching the vacuum pump can lead to burns.

Before performing any work on the vacuum pump:

- Allow the vacuum pump to cool down.
- Wear personal protective equipment.

-
- Remove safety guard.
-



-
- Manually clean the inside of the safety guard.

 - Manually clean the inside of the housing.

 - Perform quick disinfection of the inside of the safety guard.

-
- Perform quick disinfection of the inside of the housing.
 - Do not spray directly onto cables, contacts and electrical components.
-
- Fasten the safety guard.
-

Disinfect the machine and the floor

-
- Perform low pressure disinfection of the floor.
-
- Open the chamber lid.
-

NOTICE **Danger of material damage!**

Penetration by foreign matter (e.g. liquids, product residue, foreign bodies) will damage the vacuum pump. Damage can cause faults in the machine, which in turn can result in reject packs.

- Do NOT spray directly on the covers of the suction openings in the chamber.
-

-
- Perform quick disinfection of the machine.
-
- Leave the chamber lid open to dry.
-

Complete the cleaning

-
- Remove the plastic bag for protecting sensitive components.
-
- Remove the plastic bag from the mains plug.
-
- Dispose of plastic bags properly. For reasons of hygiene, never reuse bags.
-
- Insert the dry chamber lid gasket in the groove of the lid.
-



- If the chamber lid gasket or groove is wet, dry with a new cloth or sterile compressed air.
 - During insertion, do not stretch the chamber lid gasket.
-

-
- Smooth out chamber lid gasket.
-



-
- Attach or install the following components:
 - Sealing bar.
 - Filling plate.
 - Sloping insert with support angle.
-

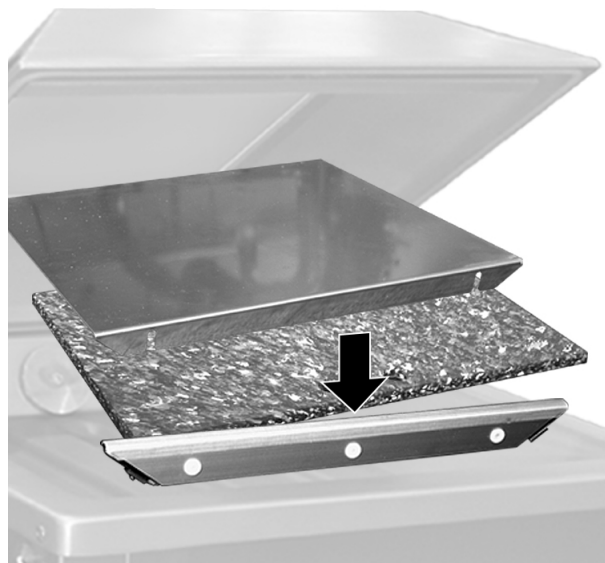

-
- Open all stop-cocks in the supply lines.
-
- Connect the machine to the mains electricity.
-
- If the external vacuum pump has its own power supply, have the external vacuum pump connected to the mains electricity by a qualified electrician.
-
- Perform quick disinfection of the whole loading area.
-

-
- Clean the cleaning devices (e.g. rubber wipers, brushes).

 - Place cleaning devices in disinfectant solution.

 - Unpack the film pouches and lay them ready.

 - Switch on the machine.

 - Close and press down the chamber lid. Observe the pressure shown in the display.
 - The pressure drops: the chamber is airtight.
 - The pressure does not drop: the chamber is not airtight.

 - If the chamber is not airtight, check the chamber lid gasket:
 - Smooth out chamber lid gasket.
 - Perform quick disinfection of the chamber lid gasket.

6.3 Care products table

Recommended care products:

Type	Manufacturer	Designation	
Cleansers, neutral	Ecolab Europa	P3-topax 12	
	Ecolab USA	Quorum Pink II	
	Diversey Europe		Shureclean VK10
			JD Shureclean Plus VK9
	Diversey USA		Shureclean VK10
			JD Shureclean Plus VK9
Cleansers, alkaline	Ecolab Europa	P3-topactive LA	
	Diversey Europe	JD Ultraclean VK3	
		Diverfoam SMS HD VF22	
	Diversey USA	JD Ultraclean VK3	
		Diverfoam SMS HD VF22	
	Cleansers (CIP cleaning), alkaline	Diversey Europe	Supergel VG3
Diversey USA			
Cleansers, acidic	Ecolab Europa	P3-topax 52	
		P3-topax 56	
	Ecolab USA	Quorum Red	
		Foam shine	
	Diversey Europe	JD Acifoam VF10	

Type	Manufacturer	Designation
	Diversey USA	
Cleansers (CIP cleaning), acidic	Diversey Europe	Acigel
	Diversey USA	JD Acifoam VF10
Disinfectants	Ecolab Europa	P3-topax 91
		P3-topax 990
	Ecolab USA	Ster-Bac
	Diversey Europe	JD Divosan extra VT55
		JD Suredis VT1
	Diversey USA	JD Divosan extra VT55
JD Suredis VT1		
Disinfectants (CIP cleaning)	Diversey Europe	TEGO 2000 VT25
	Diversey USA	Formula C
Disinfectants (alcohol-based)	Ecolab Europa	P3-alcodes
	Diversey Europe	JD Divodes FG VT29
	Diversey USA	
Anti-corrosion agents	Esso	Primol 352
	Castrol	Optimol F+D Fluid Spray
	Klüber Lubrication	Klüberfood NH1 K 32
Stainless steel care products	Ecolab Europa	P3-proguard MC
Decalcifying agents	Ecolab Europa	P3-horolith PA
	Ecolab USA	P3-aquascale
	Diversey Europe	JD Descale VA1
		JD aluminium wash VA3
	Diversey USA	JD Descale VA1
		JD aluminium wash VA3

All recommended anti corrosion agents and stainless steel care products are food compatible.

Buying source:

- Ecolab: www.ecolab.com
- Diversey: www.diversey.com
- Esso: www.exxonmobil.com
- Castrol: www.castrol.com
- Klüber Lubrication: www.klueber.com

7 Maintenance



Dangerous voltage!

Switching off the machine does not rid it of electrical current. Touching electrically charged components can cause serious or even fatal injuries.

Before performing any cleaning or service work:

- Disconnect the machine's power supply from the mains electricity.
- Have work in the control cabinet performed by authorised technicians only.



Info

Observe the safety instructions, see Section 1 "SAFETY". Clean the machine after maintenance work and repairs and disinfect if necessary.

7.1 Maintenance schedule

As needed

		Page	Completed
Entire machine	Perform intermediate disinfection	93	
Entire machine	Perform a wipe test	93	
Vacuum sensor	Exchanging the filter	96	
Vacuum filter (option)	Change	96	

Every 8 operating hours or daily

		Page	Completed
Entire machine	Visual inspection	92	
Entire machine	Alkaline cleaning and disinfection	93	
Entire machine	Intensive cleaning	93	
Chamber lid viewing window	Visual inspection	93	
Chamber lid gasket	Visual inspection	93	
Sealing bars	Visual inspection	94	
Internal vacuum pump	Checking oil level, topping up	94	

		Page	Completed
External vacuum pump	Checking oil level, topping up	94	
Basic setting	Checking, adjusting	96	

Every 50 operating hours or weekly

		Page	Completed
Entire machine	Acidic cleaning and disinfection	93	
Connections	Visual inspection	94	
Internal vacuum pump	Visual inspection	95	
External vacuum pump	Visual inspection	95	
Vacuum system	Check	96	

Every 1000 operating hours or yearly

		Page	Completed
Vacuum pump type MRP60	Oil change	96	
Vacuum pump type MRP60	Exchanging the air de-oiling element	96	
Vacuum pump type R5-RAxxx	Changing the oil and oil filter	96	
Vacuum pump type R5-RAxxx	Exchanging the air de-oiling element	96	
Entire machine	Check the age	97	

7.2 Maintenance recommendation

7.2.1 Entire machine - Visual inspection

- Check the entire machine for any external signs of damage.
- Check that all safety labels are present.
- Check that all safety devices are attached and undamaged.

7.2.2 Entire machine - Perform intermediate disinfection

- Perform intermediate disinfection regularly during operation (e.g. before or immediately after short breaks), see Section 6 "CLEANING".
-

7.2.3 Entire machine - Alkaline cleaning and disinfection

- See company cleaning guidelines.
 - See the cleaning measures specified by the manufacturer, see Section 6 "CLEANING".
-

7.2.4 Entire machine - Perform a wipe test

- Check the result of the cleaning and disinfection by means of a wipe test.
See the company cleaning guidelines and recommendations, see Section 6 "CLEANING".
-

7.2.5 Entire machine - Acidic cleaning and disinfection

- See company cleaning guidelines.
 - See the cleaning measures specified by the manufacturer, see Section 6 "CLEANING".
-

7.2.6 Entire machine - Intensive cleaning

- See company cleaning guidelines.
 - Check the components described in Intensive Cleaning for contamination.
 - If there is any contamination perform intensive cleaning, see Section 6 "CLEANING".
-

7.2.7 Chamber lid viewing window - Visual inspection

- Check the viewing window in the chamber lid for damage (e.g. scratches, cracks).
 - If the viewing window in the chamber lid is damaged have it replaced immediately by the manufacturer.
-

7.2.8 Chamber lid gasket - Visual inspection

- Check chamber lid gasket for damage.

-
- Have the chamber lid gasket replaced by the MULTIVAC service department if necessary.
-

7.2.9 Sealing bars - Visual inspection

- Check sealing bar for damage.
 - If necessary, replace the sealing bar, see Section 7.7 "REPLACE THE SEALING BAR".
-

7.2.10 Connections - Visual inspection

- Switch off the machine.
 - Disconnect the machine from the mains electricity.
 - Check power cable for damage.
 - If present, check that the supply line for inert gas is fitted tightly and undamaged.
-

7.2.11 Internal vacuum pump - Checking oil level, topping up

- Check oil level, see Section 3.2 "INITIAL START-UP".
 - If water is present in the oil, notify MULTIVAC Service.
 - If necessary, refill oil, see Section 7.3.2 "ADD OIL TO THE VACUUM PUMP".
-

7.2.12 External vacuum pump - Checking oil level, topping up

- Have a qualified electrician disconnect the vacuum pump from the mains electricity.
-



Burn hazard!

The surface of the vacuum pump can reach temperatures of over 70 °C during operation.

Touching the vacuum pump can lead to burns.

Before performing any work on the vacuum pump:

- Allow the vacuum pump to cool down.
 - Wear personal protective equipment.
-

- Check the oil level in the oil sight glass, Refer to the manual of the pump manufacturer.
-

-
- If water is present in the oil, notify MULTIVAC Service.
-
- If necessary, fill with oil; see the manual of the pump manufacturer.
-
- Have the vacuum pump connected to the mains electricity by a qualified electrician.
-

7.2.13 Internal vacuum pump - Visual inspection

- Switch off the machine.
-
- Disconnect the machine from the mains electricity.
-



Burn hazard!

The surface of the vacuum pump can reach temperatures of over 70 °C during operation.

Touching the vacuum pump can lead to burns.

Before performing any work on the vacuum pump:

- Allow the vacuum pump to cool down.
 - Wear personal protective equipment.
-

- Remove the safety guard on the back of the machine.
-
- Check that all connections are fitted tightly and undamaged.
-
- Fasten the safety guard.
-

7.2.14 External vacuum pump - Visual inspection

- Have a qualified electrician disconnect the vacuum pump from the mains electricity.
-



Burn hazard!

The surface of the vacuum pump can reach temperatures of over 70 °C during operation.

Touching the vacuum pump can lead to burns.

Before performing any work on the vacuum pump:

- Allow the vacuum pump to cool down.
 - Wear personal protective equipment.
-

- Check that all connections are fitted tightly and undamaged.
-
- Have the vacuum pump connected to the mains electricity by a qualified electrician.
-

7.2.15 Vacuum pump type MRP60 - Oil change

- Change the oil in the vacuum pump,.
-

7.2.16 Vacuum pump type MRP60 - Exchanging the air de-oiling element

- Change the air de-oiling element, see Section 7.4 "CHANGE THE AIR DE-OILING ELEMENT MRP60".
-

7.2.17 Vacuum pump type R5-RAxxx - Changing the oil and oil filter

- Have MULTIVAC Service change the oil and oil filter.
-

7.2.18 Vacuum pump type R5-RAxxx - Exchanging the air de-oiling element

- Have the air de-oiling element changed by the MULTIVAC service department.
-

7.2.19 Vacuum sensor - Exchanging the filter

- Exchanging the vacuum sensor filter, see Section 7.6 "EXCHANGING THE VACUUM SENSOR FILTER".
-

7.2.20 Basic setting - Checking, adjusting

- For the gas flushing option: Check the operating pressure for sealing and adjust if necessary, see Section 5 "ADJUSTMENT WORK AND SETUP".
 - Check input pressure of inert gas (option), adjust if necessary, see "Technical specifications".
-

7.2.21 Vacuum system - Check

- Perform a vacuum test, see Section 7.5 "PERFORMING THE VACUUM TEST".
-

7.2.22 Vacuum filter (option) - Change

- Switch off the machine.
-

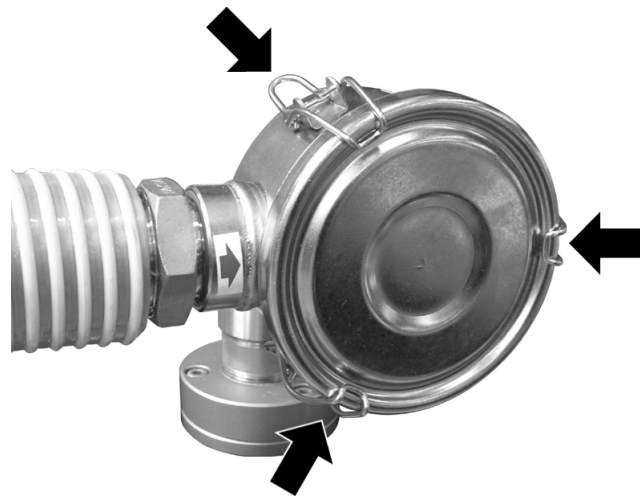

-
- Open the clamp locks on the filter housing.
 - Take off the lid.
-



-
- Remove the vacuum filter.
 - Insert a new vacuum filter.
 - Attach the lid.
 - Close the filter housing with the clamp locks.
-

7.2.23 Entire machine - Check the age

- Read the year of manufacture on the type plate.
 - If the machine is older than 19 years:
 - Shut down the machine.
 - Have the safety functions checked by MULTIVAC Service.
-

7.3 Change the oil in the vacuum pump MRP60

7.3.1 Drain oil

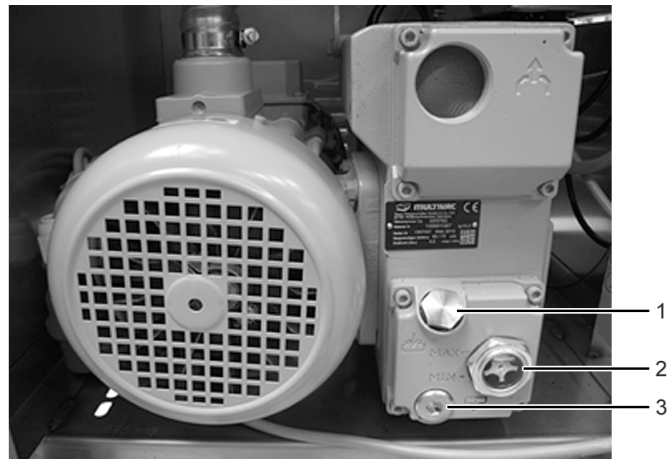

Fig. 44: Design of vacuum pump

- 1 Screw plug of fill opening
- 2 Oil sight glass
- 3 Screw plug of drain opening

-
- Switch off the machine.
-
- Disconnect the machine from the mains electricity.
-
- Allow the machine and vacuum pump to cool down for 1 hour.



Burn hazard!

The surface of the vacuum pump can reach temperatures of over 70 °C during operation.

Touching the vacuum pump can lead to burns.

Before performing any work on the vacuum pump:

- Allow the vacuum pump to cool down.
 - Wear personal protective equipment.
-
- Remove the safety guard on the back of the machine.
-
- Hold the liquid container (e.g. an empty oil bottle) under the drain opening.
-
- Unscrew the screw plug.
-
- Drain the oil completely.
-
- Wipe off any oil from the machine.

-
- Screw in the screw plug.
-
- Dispose of old oil properly.
-
- Fill the vacuum pump with new oil, see Section 7.3.2 "ADD OIL TO THE VACUUM PUMP".
-
- Fasten the safety guard.
-

7.3.2 Add oil to the vacuum pump

Adding oil to the internal vacuum pump



Fig. 45: Design of vacuum pump

- 1 Screw plug of fill opening
- 2 Oil sight glass
- 3 Screw plug of drain opening

-
- Switch off the machine.
-
- Disconnect the machine from the mains electricity.
 - External vacuum pump: If the external vacuum pump is connected directly to the mains electricity, have the vacuum pump disconnected from the mains electricity by a trained and qualified electrician.
-

**Burn hazard!**

The surface of the vacuum pump can reach temperatures of over 70 °C during operation.

Touching the vacuum pump can lead to burns.

Before performing any work on the vacuum pump:

- Allow the vacuum pump to cool down.
- Wear personal protective equipment.

-
- Remove the safety guard on the back of the machine.
-
- Unscrew the screw plug of the oil fill opening.
-
- Fill the vacuum pump with oil up to the middle of the oil sight glass. For lubricants, see the lubricant table.
-
- Check the oil level on the oil sight glass.
-
- If the oil level is under minimum, add oil. If the oil level is between minimum and maximum, the oil level is okay.
-

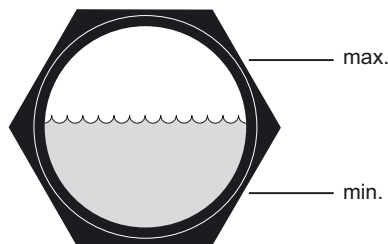

-
- Replace the sealing ring in the screw plug.
-
- Insert the screw plug with the sealing ring in the fill opening and screw it tight.
-
- Fasten the safety guard.
-
- Connect the machine to the mains electricity.
-
- Switch on the machine.
-
- Check the oil level after a couple of machine cycles.
-

7.4 Change the air de-oiling element MRP60

-
- Switch off the machine.
-
- Disconnect the machine from the mains electricity.
-



Burn hazard!

The surface of the vacuum pump can reach temperatures of over 70 °C during operation.

Touching the vacuum pump can lead to burns.

Before performing any work on the vacuum pump:

- Allow the vacuum pump to cool down.
- Wear personal protective equipment.

- Allow the vacuum pump to cool down.



Burn hazard!

The surface of the vacuum pump can reach temperatures of over 70 °C during operation.

Touching the vacuum pump can lead to burns.

Before performing any work on the vacuum pump:

- Allow the vacuum pump to cool down.
- Wear personal protective equipment.

- Remove the safety guard on the back of the machine.

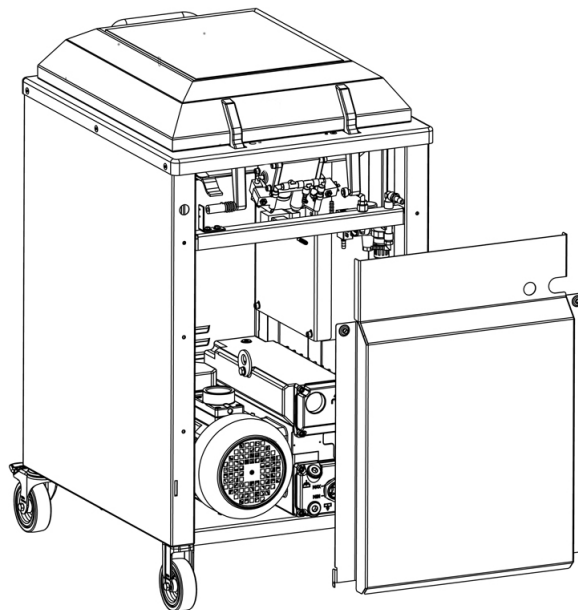

- Unscrew the screws and remove the cover.

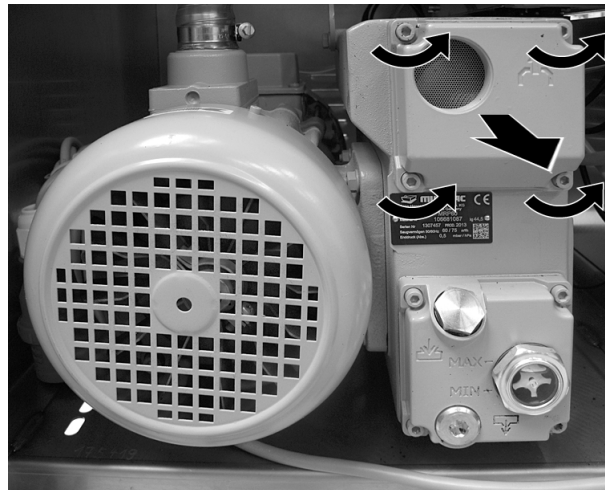

-
- Pull out the air de-oiling element.
-

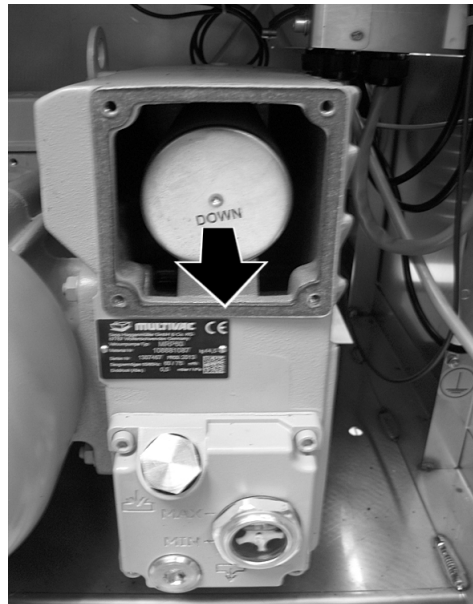

-
- Insert a new air de-oiling element. Make sure the position of the air de-oiling element is correct. Arrow points downwards.
-
- Fasten the cover with the screws.
-

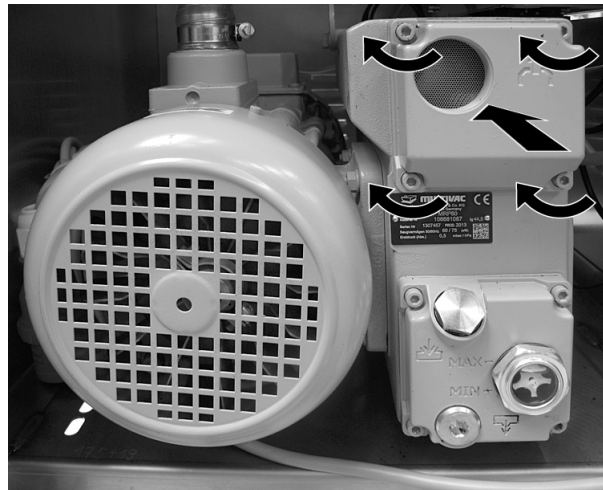

-
- Fasten the safety guard on the back of the machine.
-

7.5 Performing the vacuum test

- Call up the "Service" menu.
 - Call up the "test" menu.
 - Select *Vacuum test*.
 - Switch on the *vacuum test*.
 - Return to the status display.
 - Close and press down the chamber lid.
 - The evacuation system is being checked.
 - The processes in the machine run automatically.
 - The corresponding diagnostic message appears.
 - The chamber lid opens.
 - Acknowledge the diagnostic message.
 - The vacuum test is switched off.
 - If the vacuum test is not successful, see the displayed diagnostic message to correct the fault, see Section 8 "TROUBLESHOOTING".
-

7.6 Exchanging the vacuum sensor filter

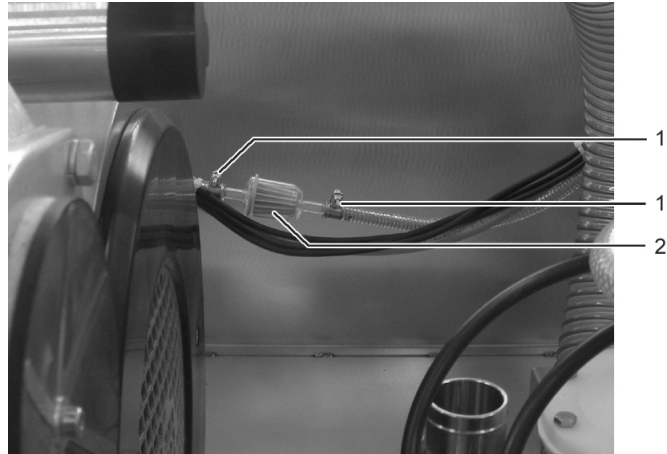

Fig. 46: Filter in measuring line of vacuum sensor

- 1 Clamp
- 2 Filter

-
- Switch off the machine.
-
- Disconnect the machine from the mains electricity.
-
- Remove safety guard.
-
- Release the clamp in front of and after the filter.
-
- Replace the filter.
-
- Fasten the filter with the clamps.
-
- Fasten the safety guard.
-

7.7 Replace the sealing bar

7.7.1 Remove the sealing bar

-
- Switch off the machine.
-
- Disconnect the machine from the mains electricity.
-
- Open the chamber lid.
-
- Let the sealing bar cool down.
-
- Pull out the sealing bar.
-



7.7.2 Install the sealing bar

- Disconnect the machine from the mains electricity.
- Install the sealing bar on the carriers.



- Install the sealing bar in such a way that the screws on the sealing bar point to the middle of the chamber.

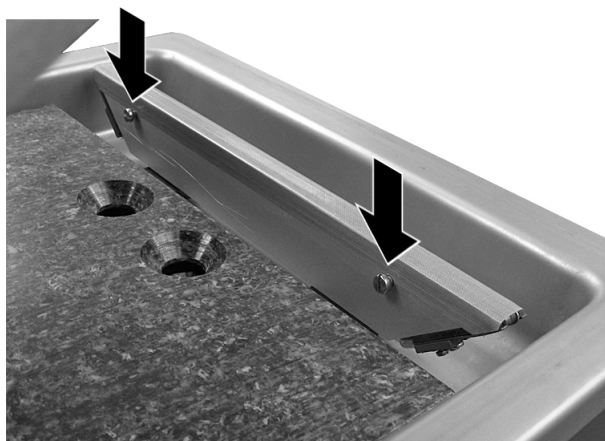

7.8 Lubricant table



Info

The lubricants, which are recommended by MULTIVAC, are tailored ideally to the purpose and use. Damage to equipment or impairment of performance, e.g. increased wear and corrosion or similar, which is caused by use of inappropriate lubricants, is not covered by our warranty.

Recommended lubricants:

Lubrication point	Type	Manufacturer	Designation	Designation	MULTIVAC part number	Quantity
Vacuum pump	Oil	Shell	Shell Corena P100	-	9111111450 2	1 l
Vacuum pump	Oil	Shell	Shell Corena P100	-	9111111450 1	20 l

8 Troubleshooting



Injury hazard!

Ignorance of proper machine handling is very dangerous. Improper handling can lead to serious injuries.

For all service and repair work:

- Make sure you observe the safety instructions and accident prevention regulations.
- Disconnect the unit's power supply from the mains electricity.
- Only qualified electricians are permitted to work on electrical modules.
- Service and repair work should be carried out by authorised technicians only.

8.1 Faults with diagnostic message

Symptom	Cause	Solution
20	<ul style="list-style-type: none"> • Mechanical fracture of the spring in the chamber lid lifting mechanism. The fracture is detected as a faulty electrical interruption. 	<ul style="list-style-type: none"> • Replace the spring.
	<ul style="list-style-type: none"> • Interruption of electrical contact. 	<ul style="list-style-type: none"> • Have the electrical link between the spring and the DI15 monitoring input checked by a trained and qualified electrician, and if necessary have the link established again.
Symptom	Cause	Solution
21	<ul style="list-style-type: none"> • Interruption of electrical contact. 	<ul style="list-style-type: none"> • Have the electrical link between the spring and the DI14 monitoring input checked by a trained and qualified electrician, and if necessary have the link established again.
Symptom	Cause	Solution
24	<ul style="list-style-type: none"> • Monitoring of the safety frame was triggered. 	<ul style="list-style-type: none"> • Remove the obstruction and if necessary align the safety frame.
25	<ul style="list-style-type: none"> • Chamber lid jams. 	<ul style="list-style-type: none"> • Eliminate the mechanical fault.

Symptom	Cause	Solution
	<ul style="list-style-type: none"> The actuating voltage has failed or the actuator is defective. 	<ul style="list-style-type: none"> Have the actuating voltage and actuator checked by a trained and qualified electrician.
Symptom	Cause	Solution
67	<ul style="list-style-type: none"> Vacuum pump does not switch off. 	<ul style="list-style-type: none"> Notify MULTIVAC Service.
	<ul style="list-style-type: none"> Ventilation valve does not open. 	<ul style="list-style-type: none"> Notify MULTIVAC Service.
68	<ul style="list-style-type: none"> No inert gas available or almost depleted. 	<ul style="list-style-type: none"> Connect inert gas or ensure that there is sufficient gas supply (e.g. change gas cylinder).
	<ul style="list-style-type: none"> Stop-cock for the gas supply is closed. 	<ul style="list-style-type: none"> Open the stop-cock for the gas supply.
	<ul style="list-style-type: none"> Gas hose has a kink in it. 	<ul style="list-style-type: none"> Remove the kink in the gas hose.
	<ul style="list-style-type: none"> Value for the <i>gas flushing pressure</i> is set such that it cannot be reached. 	<ul style="list-style-type: none"> Correct the value for <i>Gas flushing pressure</i>.
	<ul style="list-style-type: none"> The vacuum sensor is incorrectly calibrated. 	<ul style="list-style-type: none"> Notify MULTIVAC Service.
	<ul style="list-style-type: none"> Vacuum sensor is defective. 	<ul style="list-style-type: none"> Notify MULTIVAC Service.
	<ul style="list-style-type: none"> Gas valve does not open. 	<ul style="list-style-type: none"> Notify MULTIVAC Service.
69	<ul style="list-style-type: none"> Value for the <i>Evacuation pressure</i> is set so low that it cannot be reached. 	<ul style="list-style-type: none"> Correct the value for <i>Evacuation pressure</i>.
	<ul style="list-style-type: none"> Vacuum hose between the chamber and the vacuum sensor is clogged, missing or leaking. 	<ul style="list-style-type: none"> Notify MULTIVAC Service.
	<ul style="list-style-type: none"> Vacuum hose is loose, leaking or clogged. 	<ul style="list-style-type: none"> Notify MULTIVAC Service.
	<ul style="list-style-type: none"> Chamber lid gasket is not airtight. 	<ul style="list-style-type: none"> Notify MULTIVAC Service.
	<ul style="list-style-type: none"> Vacuum sensor is defective. 	<ul style="list-style-type: none"> Notify MULTIVAC Service.

Symptom	Cause	Solution
	<ul style="list-style-type: none"> Vacuum pump was not triggered, overload current relay has signalled or vacuum pump is defective. 	<ul style="list-style-type: none"> Notify MULTIVAC Service.
	<ul style="list-style-type: none"> Vacuum pump is leaky. 	<ul style="list-style-type: none"> Notify MULTIVAC Service.
	<ul style="list-style-type: none"> Filter in the line to the vacuum sensor is dirty and blocked. 	<ul style="list-style-type: none"> Notify MULTIVAC Service.
80	<ul style="list-style-type: none"> Leak in hose connections. 	<ul style="list-style-type: none"> Notify MULTIVAC Service.
	<ul style="list-style-type: none"> Leak in vacuum hose. 	<ul style="list-style-type: none"> Notify MULTIVAC Service.
	<ul style="list-style-type: none"> The vacuum sensor and associated line is leaking. 	<ul style="list-style-type: none"> Notify MULTIVAC Service.
81	<ul style="list-style-type: none"> Sealing diaphragm leaks. 	<ul style="list-style-type: none"> Notify MULTIVAC Service.

8.2 Faults without diagnostic message

Symptom	Cause	Solution
Machine does not run.	<ul style="list-style-type: none"> Machine is switched off. 	<ul style="list-style-type: none"> Switch on the machine.
	<ul style="list-style-type: none"> Mains plug is unplugged. 	<ul style="list-style-type: none"> Plug in the mains plug.
Chamber lid does not remain closed despite pump running.	<ul style="list-style-type: none"> Chamber lid pressed closed too briefly. 	<ul style="list-style-type: none"> Press chamber lid closed more firmly and for longer.
	<ul style="list-style-type: none"> Chamber lid gasket is dirty. 	<ul style="list-style-type: none"> Clean the chamber lid gasket.
	<ul style="list-style-type: none"> Chamber lid gasket is damaged. 	<ul style="list-style-type: none"> Notify MULTIVAC Service.
Seal seam not airtight - pack is slack.	<ul style="list-style-type: none"> The time <i>Fill diaphragm</i> is set too low. 	<ul style="list-style-type: none"> Correct the time <i>Fill diaphragm</i>.
	<ul style="list-style-type: none"> <i>Sealing time</i> is incorrectly set. 	<ul style="list-style-type: none"> Correct <i>Sealing time</i>.
	<ul style="list-style-type: none"> Sealing pressure is incorrectly set. 	<ul style="list-style-type: none"> Correcting the sealing pressure.
	<ul style="list-style-type: none"> Pouch neck is clamped by chamber lid. 	<ul style="list-style-type: none"> Insert the film pouch so that the pouch neck lies within the chamber.
	<ul style="list-style-type: none"> Seal seam is dirty. 	<ul style="list-style-type: none"> Keep sealing bar and film pouch clean.
	<ul style="list-style-type: none"> Pack not air-tight. 	<ul style="list-style-type: none"> Use a new film pouch.
	<ul style="list-style-type: none"> Film pouch not suitable. 	<ul style="list-style-type: none"> Use a film pouch suitable for sealing.

Symptom	Cause	Solution
	<ul style="list-style-type: none"> The sealing force is not sufficient. 	<ul style="list-style-type: none"> Without the inert gas option: check settings. Sufficient sealing force is only achieved if the target pressure target value is set under 400 mbar. Inert gas option: Increase the pressure on the gas cylinder, and then gradually increase the sealing force on the sealing pressure regulator.
	<ul style="list-style-type: none"> Sealing bar damaged. 	<ul style="list-style-type: none"> Replace sealing bar.
Pressure target value is not reached.	<ul style="list-style-type: none"> The set pressure target value is not achieved (e.g. product contains water). 	<ul style="list-style-type: none"> Set a higher pressure target value.
	<ul style="list-style-type: none"> Chamber lid gasket is dirty. 	<ul style="list-style-type: none"> Clean the chamber lid gasket.
	<ul style="list-style-type: none"> Insufficient oil quantity or oil in the vacuum pump is too old. 	<ul style="list-style-type: none"> Fill or replace oil.
	<ul style="list-style-type: none"> Chamber lid gasket is damaged. 	<ul style="list-style-type: none"> Notify MULTIVAC Service.
	<ul style="list-style-type: none"> Evacuation system is leaking. 	<ul style="list-style-type: none"> Notify MULTIVAC Service.
Odour or smoke.	<ul style="list-style-type: none"> Air de-oiling element is defective. 	<ul style="list-style-type: none"> Change air de-oiling element.
	<ul style="list-style-type: none"> Oil return valve of vacuum pump is blocked. 	<ul style="list-style-type: none"> Notify MULTIVAC Service.

9 Shutdown, transport, storage



Info

Observe the safety instructions, see Section 1 "SAFETY".

9.1 Shutting down the machine

9.1.1 Cleaning the machine

- Perform intensive cleaning of the machine, see Section 6.2 "CLEANING THE MACHINE".
-

9.1.2 Closing and disconnecting supply lines



Dangerous voltage!

Switching off the machine does not rid it of electrical current. Touching electrically charged components can cause serious or even fatal injuries.

Before performing any cleaning or service work:

- Disconnect the machine's power supply from the mains electricity.
 - Have work in the control cabinet performed by authorised technicians only.
-

- Switch off the machine.
-

- Disconnect the machine from the mains electricity.
-

- Close stop valve for the gas supply, if present.
-

- If present, remove the gas hose from the inert gas connection.
-

- Close lid.
-

- Lock lid in place.
-

9.1.3 Preserving the machine

- Preserving the machine, see Section 6.1.7 "CORROSION PROTECTION AND LUBRICATION".
-

9.2 Transporting the machine

9.2.1 Transporting the machine

- Wear personal protective equipment.

-
- Shut down the machine.
-
- Use suitable and adequately sized load lifting equipment. Note here the machine dimensions and weight, see the shipping documents.
-
- Set the forklift to the widest setting.
-
- Position the load lifting equipment along the longer side of the machine.
 - While doing so establish the machine's centre of gravity. It can lie outside the centre point of the machine.
-
- Secure the machine on the load lifting equipment against tilting and falling over by using technically risk free transportation safety attachments.
-



Injury hazard!

Incorrect transport can cause the machine to fall or tip over. Standing in the danger zone can lead to serious injuries or even death.

- Do NOT stand under suspended loads.
 - Lift the machine only at the designated points.
 - Bear in mind the machine weight.
-

NOTICE Danger of material damage!

Incorrect transport can damage the machine. Damage can cause faults in the machine, which in turn can result in reject packs.

- Transport the machine centred on the forks.
-

NOTICE Danger of material damage!

At an inclination of more than 15°, the oil in the vacuum pump shifts.

The air de-oiling elements will get wet from the oil and become ineffective. This will damage the vacuum pump.

- Transport and set the machine down as horizontally as possible.
 - Do NOT tilt the machine.
-

- Lift the machine and transport it.
-

9.2.2 Preparing the machine for onward transport (i.e by truck)

- Wear personal protective equipment.
- Shut down the machine.
- Use suitable and adequately sized load lifting equipment. Note here the machine dimensions and weight, see the shipping documents.
- Set the forklift to the widest setting.
- Position the load lifting equipment along the longer side of the machine.
 - While doing so establish the machine's centre of gravity. It can lie outside the centre point of the machine.
- Secure the machine on the load lifting equipment against tilting and falling over by using technically risk free transportation safety attachments.



Injury hazard!

Incorrect transport can cause the machine to fall or tip over. Standing in the danger zone can lead to serious injuries or even death.

- Do NOT stand under suspended loads.
- Lift the machine only at the designated points.
- Bear in mind the machine weight.

NOTICE Danger of material damage!

Incorrect transport can damage the machine. Damage can cause faults in the machine, which in turn can result in reject packs.

- Transport the machine centred on the forks.

NOTICE Danger of material damage!

At an inclination of more than 15°, the oil in the vacuum pump shifts.

The air de-oiling elements will get wet from the oil and become ineffective. This will damage the vacuum pump.

- Transport and set the machine down as horizontally as possible.
- Do NOT tilt the machine.

- Lift up the machine.

-
- Position the machine on the wooden base.

 - Fasten the machine adequately to the wooden base.

 - Wrap or cover the machine with appropriate packaging material.

 - Position the load lifting equipment under the wooden base.
 - While doing so establish the machine's centre of gravity. It can lie outside the centre point of the machine.

 - Secure the machine on the load lifting equipment against tilting and falling over by using technically risk free transportation safety attachments.



Injury hazard!

Incorrect transport can cause the machine to fall or tip over. Standing in the danger zone can lead to serious injuries or even death.

- Do NOT stand under suspended loads.
- Lift the machine only at the designated points.
- Bear in mind the machine weight.

NOTICE Danger of material damage!

Incorrect transport can damage the machine. Damage can cause faults in the machine, which in turn can result in reject packs.

- Transport the machine centred on the forks.

NOTICE Danger of material damage!

At an inclination of more than 15°, the oil in the vacuum pump shifts.

The air de-oiling elements will get wet from the oil and become ineffective. This will damage the vacuum pump.

- Transport and set the machine down as horizontally as possible.
- Do NOT tilt the machine.

-
- Lift the machine and position on the transportation to be used for the onward transport.

9.3 Storing the machine

-
- Shutting down the machine.

 - Select a suitable storage site.

- Observe the ambient conditions for storing the machine, see Technical specifications.
 - Ensure that the location site is of adequate load-bearing capacity and keep the weight of the unit in mind, see Technical specifications.
-

- If necessary, cover the machine with film.
-

10 Disposal

10.1 Disposing of the machine



Info

- Sealing bars can be reused on other machines of the same series.
- If disposal of the machine is not handled by the manufacturer, dispose of the machine as described below.

➤ Disconnect the machine from the mains electricity, see Section 9.1.2 "CLOSING AND DISCONNECTING SUPPLY LINES".

➤ Drain oil from the vacuum pump, see Section 7.3.1 "DRAIN OIL".

➤ Dispose of the materials properly, observing all legal and company-internal regulations regarding environmental protection.

10.2 Dispose of operating materials

10.2.1 Disposing of oil and grease

NOTICE **Protect the environment!**

Operating materials and working equipment are environmentally harmful.

Improper disposal is harmful to the environment.

- Handle operating materials and working equipment properly.
- Dispose of operating materials and working equipment at suitable collection points.
- Observe the environmental directives.

➤ Handle operating materials and working equipment properly and dispose of them in a professional manner.



Info

Excerpt from the disposal directive:

- It is prohibited to mix used oil with other waste.
- Used oils may NOT be mixed with each other.
- Used oil filters should be collected, stored, transported and disposed of separately from other waste.

10.2.2 Disposing of packaging materials



Info

Packaging materials are resource materials that can be recycled.

- Improper disposal is harmful to the environment.
- Films should be collected for recycling.
- Follow the disposal instructions of the packaging material manufacturer.

-
- Handle packaging materials properly and dispose of them in a professional manner.
-



Info

Packaging materials are resource materials that can be recycled.

- Improper disposal is harmful to the environment.
- Films should be collected for recycling.
- Follow the disposal instructions of the packaging material manufacturer.

10.2.3 Dispose of chemicals



WARNING

Chemical burn hazard!

Cleansers are caustic. Caustic effects are NOT noticed immediately.

Contact with the skin can cause burns.

- Wear the prescribed personal protective equipment when handling cleansers.
 - Observe the manufacturer's instructions.
-



WARNING

Fire hazard!

Alcohol-based disinfectants are highly flammable.

Fire, naked light or smoking ignites the disinfectant and can thus cause fires.

- When disinfecting the machine, flames or naked lights are prohibited.
 - Smoking is prohibited.
 - Observe the instructions of the disinfectant manufacturer.
-

- Handle cleansers and disinfectants properly and dispose of them in a professional manner.
-



Info

Improper disposal is harmful to the environment.

- Observe the safety data sheets of the cleanser and disinfectant manufacturers.
- Follow the disposal instructions of the cleanser and disinfectant manufacturers.
- Observe regionally applicable disposal regulations.

11 Spare parts

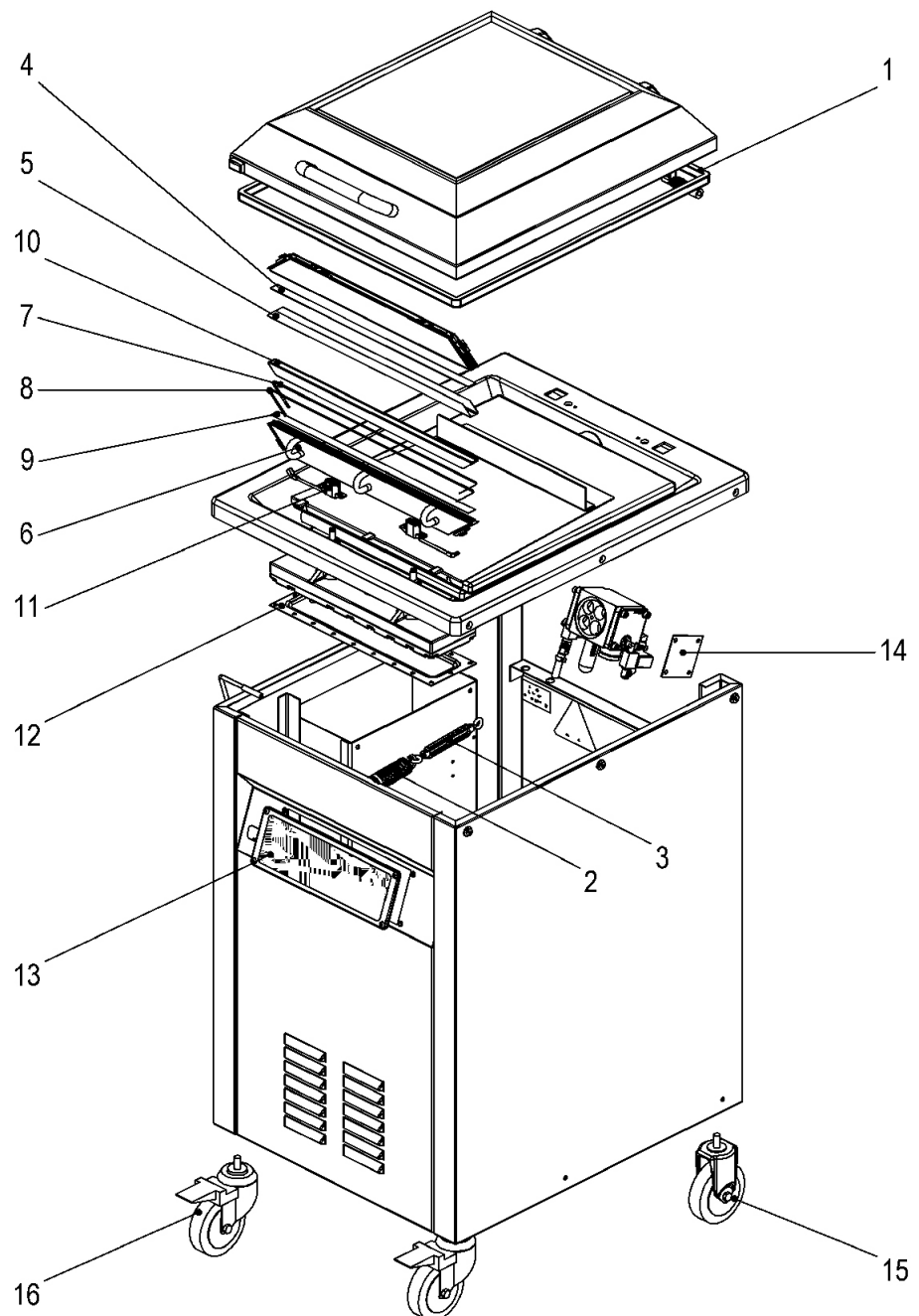

Fig. 47: Spare parts drawing (SAP-DIS 16000023384)

Item	Material number	Designation	Quantity and unit of measurement
1	81863140000	Profile thread (Chamber lid gasket)	2.2 m
2	19784322700	Tension spring (d=27 mm)	1 pc.

Item	Material number	Designation	Quantity and unit of measurement
3	19784252000	Tension spring (d=20 mm)	1 pc.
4	81863151040	Profile thread	0.45 m
5	81848121000	Teflon tape 0.13 mm x 16 mm	0.45 m
6	11131213701	Sealing bar, complete	1 pc.
7	11131198110	Heating band	0.61 m
8	85662802090	Severing wire	0.61 m
9	81848121001	Teflon tape 0.25 mm x 16 mm	0.57 m
10	81848121006	Teflon tape 0.13 mm x 40 mm	0.53 m
11	85123126100	Contact bushing	2 pc.
12	11181798080	Diaphragm	1 pc.
13	105326625	Machine controls	1 pc.
14	11181798040	Diaphragm	1 pc.
15	81948111102	Fixed castor	2 pc.
16	81948111002	Swivel castor	2 pc.
17	80121408400	Maintenance set for pump RA 0025/0040 E	1 pc.
17	80121408402	Maintenance set for pump RA 0063/0100 E	1 pc.
18	11131117217	Repair kit (contains items 9, 10)	1 pc.

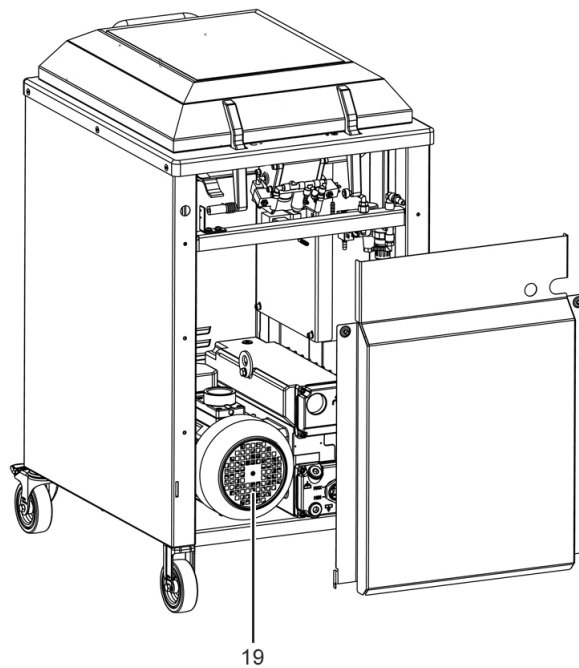
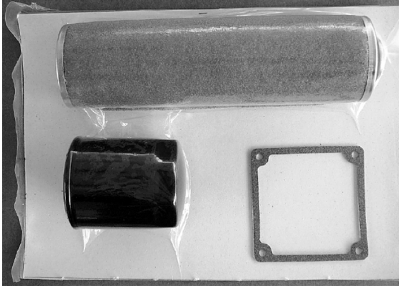
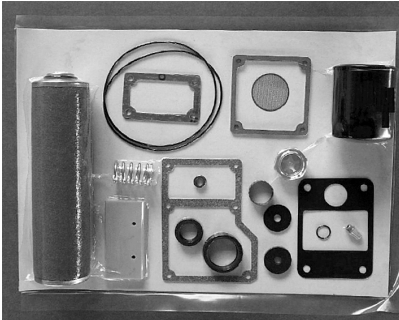

Fig. 48: Spare parts drawing

Spare parts for pumps

Item	Type	Voltage	Frequency	Material number
19	R5-RA0040	<ul style="list-style-type: none"> • 190 V - 230 V • 380 V - 460 V 	50 Hz - 60 Hz	105491013
19	R5-RA0040	<ul style="list-style-type: none"> • 230 V • 400 V 	50 Hz	106471352
19	R5-RA0040	<ul style="list-style-type: none"> • 220 V • 380 V 	60 Hz	106513735
19	R5-RA0040	220 V - 240 V	50 Hz	80121400004
19	R5-RA0063	<ul style="list-style-type: none"> • 190 V - 230 V • 380 V - 460 V 	50 Hz - 60 Hz	105491014
19	R5-RA0063	<ul style="list-style-type: none"> • 230 V • 400 V 	50 Hz	106471354
19	R5-RA0063	<ul style="list-style-type: none"> • 220 V • 380 V 	60 Hz	106513739
19	R5-RA0063	220 V - 240 V	50 Hz	80121400304

Item	Type	Voltage	Frequency	Material number
19	MRP60	175 V - 520 V	50 Hz - 60 Hz	<ul style="list-style-type: none">• Pump: 106681087• Wearing parts set, small: 106701322  <p>Fig. 49: Wearing parts set, small</p> <ul style="list-style-type: none">• Wearing parts set, large: 106715703  <p>Fig. 50: Wearing parts set, large</p>

Glossary

Automatic	<p>[Parameter of the control unit] If the function <i>Automatic</i> is set, the machine will reach the optimum evacuation time and pressure depending on the product. The automatic evacuation is suitable for the following cases:</p> <ul style="list-style-type: none">• Achieving the best possible vacuum for long shelf life.• Packing of products for which the optimum evacuation pressure is not known.• Packing of the same product but one which has varying properties (e.g. varying moisture content, varying temperature). <p>If the evacuation is automatic the value for <i>Automatic sensitivity</i> can be adapted to the product.</p>
Automatic sensitivity	<p>[Parameter of the control unit] Determines the evacuation time and the evacuation pressure reached, when evacuating with the <i>Automatic</i> function. The sensitivity is adjustable from 1 to 10. The lower the sensitivity, the lower the evacuation pressure reached. High value for <i>Automatic sensitivity</i> (value 10):</p> <ul style="list-style-type: none">• Is suitable for very moist or fluid products.• Evacuation process ends early.• Evacuation pressure reached in the pack is high. <p>Low value for <i>Automatic sensitivity</i> (value 1):</p> <ul style="list-style-type: none">• Is suitable for dry products.• Evacuation process ends late.• Evacuation pressure reached in the pack is low.
Configuration code	<p>The configuration code determines the machine characteristics and functions. It can be shown in the display. The configuration code is preset at the factory, modifications can only be made by the MULTIVAC service department.</p>
Cooling down Sealing	<p>[Parameter of the control unit] Value for the cooling down time of the seal seam. The vacuum in the chamber and the sealing pressure are maintained for this length of time. The seal seam can harden. The sealing is switched off during this time.</p>
Counter-pressure bar	<p>The counter-pressure bar is part of the sealing. During the sealing procedure, the sealing bar is pressed against the counter-pressure bar. Depending on the machine equipment, there may be a sealing bar instead of the counter-pressure bar.</p>
Cycle end	<p>[Optional] [Parameter of the control unit] Defines if evacuation or gas flushing takes place before sealing in the MRP process.</p>

Cycle time [Parameter of the control unit]
The display contains the times of the individual procedures of the last packaging procedure.

Delayed ventilation - Sealing [Parameter of the control unit]
The ventilation of the chamber begins with a delay after sealing.

Diagonal insert

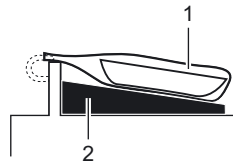

Fig. 58: Diagonal insert

- 1 Pack
- 2 Diagonal insert

The diagonal insert is used for the optimal positioning of liquid products. As a result of this the product does not spill out of the film pouch.

Distribution time - evacuation [Parameter of the control unit]
Switching interval between the completed evacuation process and the beginning of the gas flushing process. During the distribution time remaining air pockets in the products can escape before the package is sealed.

Distribution time - Gas flushing [Optional] [Parameter of the control unit]
Switching interval after the gas flushing process, during which the gas can distribute itself in the the film pouch.

Double-seam sealing [Optional]
The double-seam sealing function produces two seal seams.

Double-seam separation sealing The double-seam separation sealing function produces two seal seams. The integrated separating wire severs the pouch trim.

Evacuation Evacuation is the physical term for creating a vacuum by removing the air from a space. This reduces the oxygen content, thereby extending product shelf-life.

Evacuation pressure [Parameter of the control unit]
Is the pressure to which the film pouch and the chamber are evacuated. The pressure is measured in the chamber.

Factory settings Factory settings are preset values (default values). The factory settings are stored in recipe 30.

Fill diaphragm [Parameter of the control unit]
During this time sealing pressure is applied to the sealing diaphragm.

Gas flushing	<p>[Optional] The film pouches are filled with inert gas. Gas flushing with inert gas has the following advantages:</p> <ul style="list-style-type: none">• It extends the shelf life of the product.• It reduces oxygen content.• It avoids putting pressure on the product.
Gas flushing pressure	<p>[Optional] [Parameter of the control unit] Indicates the pressure up to which the film pouch is back filled with inert gas. Pressure is measured in the chamber.</p>
Gas flushing time	<p>[Optional] [Parameter of the control unit] Indicates the amount of time for which the film pouch will be filled with inert gas. The pressure can not be influenced by this.</p>
Hours of operation	<p>[Parameter of the control unit] Shows the time the machine has been operating. The counter begins to count as soon as the machine is switched on and can not be reset.</p>
Instructed person	<p>An instructed person is someone who has been instructed and trained in regard to the potential hazards of his or her assigned tasks, as well as in regard to the necessary safety devices, protective measures, relevant stipulations, accident prevention regulations and operating conditions, and whose competence has been demonstrated.</p>

Machine cycles

[Parameter of the control unit]

Counts the number of complete machine cycles. The counter can be modified and reset. It is used to control the quantities produced.

MCV

Fig. 53: Example diagram of MCV

1 Duration of the held vacuum (MCV Duration)

P1 Evacuation pressure

P2 Tolerance range for the evacuation pressure (MCV threshold)

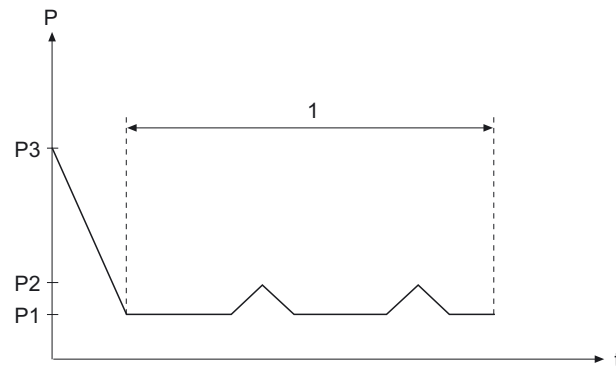
P3 Ambient pressure

During the MCV (MULTIVAC Continuous Vacuum) process, a product or a pack is exposed to a vacuum for up to 20 days. The chamber is evacuated to the set pressure, which is then maintained for the set time. If the pressure exceeds an adjustable threshold, post-evacuation takes place automatically.

MCV duration

[Parameter of the control unit]

This time determines the duration of the MCV process.

MCV threshold

[Parameter of the control unit]

If the pressure value set here is exceeded during the MCV process, further evacuation automatically takes place.

MHP

Fig. 54: Example diagram of MHP

t1 Evacuation pause

t2 Evacuation time

V1 Evacuation pressure

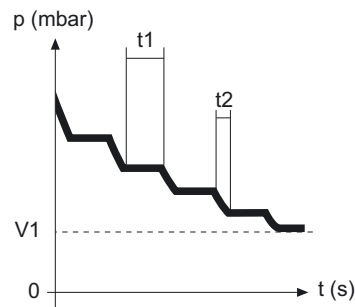
During the MHP process, evacuation takes place in several steps. The air is suctioned out for a set time (evacuation time); a set pause in suctioning (evacuation pause) follows. Afterwards, the air is further evacuated. The steps are repeated.

MHP evacuation pause [Parameter of the control unit]

Defines the duration of the intervals between two evacuation pulses during the MHP process.

MHP evacuation time [Parameter of the control unit]

Defines the duration of the evacuation pulses during the MHP process.

MPP

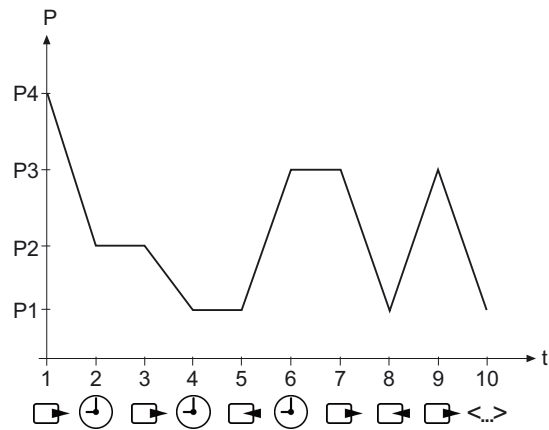

Fig. 55: Example diagram of MPP

1- Steps 1 to 10

10

P1 Evacuation pressure in steps 3, 7 and 9

P2 Evacuation pressure in step 1

P3 Gas flushing pressure in steps 5 and 8

P4 Ambient pressure

During the MPP (MULTIVAC Programmed Processing) process the progression of the evacuation curve and gas flushing curve can be freely selected. The entire procedure can be comprised of up to 30 steps, with each step assigned a function and a value.

MRP

[Optional]

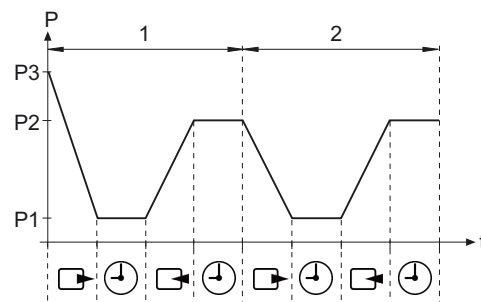

Fig. 56: Example diagram of MRP (cycle end: gas flushing)

- 1 Cycle 1
- 2 Cycle 2
- P1 Evacuation pressure
- P2 Gas flushing pressure
- P3 Ambient pressure

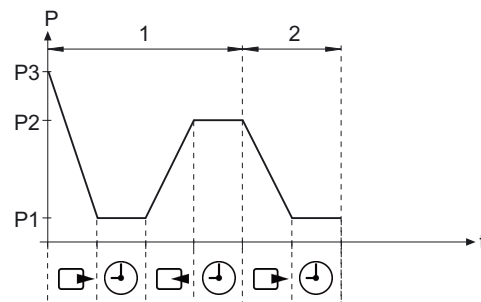

Fig. 57: Example diagram of MRP (cycle end: evacuation)

- 1 Cycle 1
- 2 Cycle 2
- P1 Evacuation pressure
- P2 Gas flushing pressure
- P3 Ambient pressure

During the MRP (MULTIVAC Repeated Processing) process, evacuation and gas flushing takes place alternately over several cycles. The machine evacuates and flushes gas to the set pressures and repeats the procedure according to the settings.

Number of cycles

[Optional] [Parameter of the control unit]

Defines how many cycles are to be completed in the MRP process. A cycle is comprised of evacuation and gas flushing. The residual oxygen content is reduced by the repeated evacuation and gas flushing.

Post-evacuation time	<p>[Parameter of the control unit]</p> <p>This time extends the evacuation process. Through this, the reached evacuation pressure is lower than the set value. This time begins, when the set pressure is reached. Suitable for damp products.</p>
Purging time, gas flushing	<p>[Optional] [Parameter of the control unit]</p> <p>During this time the vacuum valve and gas valve are opened simultaneously. On one side of the chamber a vacuum is created, on the other side gas is supplied. The film pouch is thoroughly flushed with gas. This reduces the residual oxygen content.</p>
Recipe	<p>A recipe contains the machine settings adapted for a product. The settings for a specific product can then be loaded quickly.</p>
Sealing	<p>The sealing procedure closes the evacuated film pouch to form a pack. In sealing, the pouch neck is pressed together and the sealing bar is heated. At the heated point the pouch neck melts to form a seal seam.</p> <p>The following sealing procedures are available:</p> <ul style="list-style-type: none"> • Double-seam sealing (option) • Double-seam sealing at top and bottom (option) • Double-seam separation sealing
Sealing time	<p>[Parameter of the control unit]</p> <p>During this time the film pouch is sealed. The sealing time depends on the material and the thickness of the film pouch.</p>
Sealing time max	<p>[Parameter of the control unit]</p> <p>This time determines the maximum value for the sealing time.</p>
Settings - Production Data	<p>[Parameter of the control unit]</p> <p>Shows all currently set target values.</p>

Spacer plate

Fig. 52: Filling plates

- 1 Pack
- 2 Spacer plate
- 3 Spacer plate

The product positioning height can be manually set to the height of the sealing bar by means of the spacer plates. The product is correctly positioned when the pouch neck lies half way up the pouch height. Additionally, the chamber volume is reduced and the chamber is evacuated more quickly.

standard

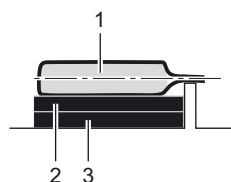
Fig. 59: Example diagram of standard process

P1 Evacuation pressure

P2 Gas flushing pressure

P3 Ambient pressure

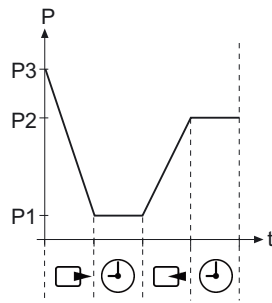
During the standard process, air is suctioned out until the set pressure is reached. Afterwards, gas is flushed at the set pressure (option).

Technician

A technician is defined as someone who, based on his/her technical training, knowledge and experience with the product and familiarity with relevant applicable norms, can evaluate the tasks delegated to him/her and recognise and avert dangers.

total cycles

[Parameter of the control unit]

Shows the completed machine cycles.

Vacuum pump - Production data

[Parameter of the control unit]

Counts the vacuum pump's hours of operation. Counting starts as soon as the vacuum pump is turned on. The display cannot be changed.

Vacuum pump running-on time

[Parameter of the control unit]

After sealing the film pouch, the vacuum pump switches off in a time-delayed manner by the amount of the running-on time. The running-on time bridges the temporary stopping of the vacuum pump. This prevents the vacuum pump from overheating due to continual switching on and off.

Vacuum test

[Parameter of the control unit]

Automatic leakage test of the vacuum system and the sealing diaphragm.

Ventilate diaphragm

[Parameter of the control unit]

During this time the sealing diaphragm is evacuated. The sealing is without sealing pressure.

Ventilation

During ventilation the pressure in the chamber adapts to the ambient pressure. As a result of this, the film pouch shrinks tightly to the product. After the chamber has been ventilated the lid opens automatically, if it is not locked. .

Ventilation pulse pressure [Parameter of the control unit]
 During the closing of the sealing unit, the chamber is ventilated until this pressure value is reached. As a result, the film pouch settles better on the product.

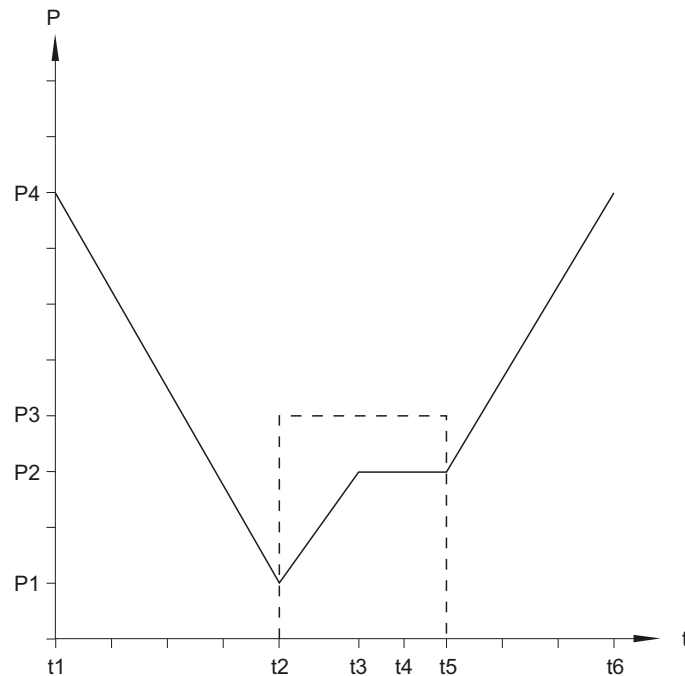

Fig. 51: Sequence diagram packaging procedure with ventilation pulse

- t1** Start evacuation procedure
- t2** The evacuation pressure is reached, the sealing unit closes, start ventilation pulse
- t3** Pressure value for ventilation pulse is reached
- t4** The film pouch is sealed
- t5** The sealing unit open, the chamber is ventilated until the ambient pressure is reached
- p1** Evacuation pressure
- p2** Pressure value for ventilation pulse
- p3** Sealing pressure
- p4** Ambient pressure

Index

A

Access authorisations, selecting 58
Access right 58
Access right, resetting 58
Access rights 38, 39
Access, blocking 58
Adjustment work 68
Against regulations 14
Air de-oiling element 46, 100, 112, 113, 114
Air humidity 42
Airtightness testing 40
Ambient conditions 42
Ambient temperature 42
Anti-corrosion agents 73
Attaching gas cylinder 51
Automatic 123
Automatic sensitivity 123
Auxiliary unit 50

B

Basic cleaning 53
Basic settings 64
Buying source 90

C

Calling up menus 57
Care products table 89
Chamber 30
Chamber lid 30
Chamber lid gasket 30
Chamber size 42
Change password 58
Cleaning 76
Cleaning device 73
Cleaning procedure 74
Cleansers 71
Configuration code 35, 123
Control cabinet 21, 22
Control terminal 30, 32
Cooling down Sealing 123
Corrosion protection 73
Counter-pressure bar 30, 123
Cycle end 123
Cycle time 124
Cycles 129

D

Daily cleaning 76
Daily disinfection 76
Danger zones 20
Delayed ventilation - sealing 124
Delivery, checking 45
Depth 42
Diagnostic display 38
Diagnostic message 107
Diagnostic message, acknowledging 33
Diagnostic number 38
Diagonal insert 124
Dimensions 42
Disinfectant 72
Disinfection 76
Display 35
Display cycle time 65
Display hours of operation 65
Display production data 64
Display total cycles 64
Display, setting 65
Disposal directive 116
Dispose of chemicals 117
Disposing of the machine 116
Distribution time - evacuation 124
Distribution time - gas flushing 124
Double-seam sealing 124
Double-seam separation sealing 124
Drain opening, oil 48, 98, 99
Dry cleaning 75
Drying packaging 40

E

Electrical circuit of the operating company 17
EMC 14
Entering basic settings 64
Error 38
Error number 38
Evacuation 124
Evacuation Pressure 124
Evacuation process, cancelling 33
External vacuum pump 50

F

Factory setting 60
Factory settings 124

- fault 109
Faults 107
Fill diaphragm 124
Fill opening, oil 48, 98, 99
Film, disposal 117
Front view 30
- G**
Gas cylinder 35
Gas flushing 125
Gas flushing pressure 125
Gas flushing process, cancelling 33
Gas flushing time 125
Gas purging 130
Gas supply 17
Grease disposal 116
- H**
Handle 30
Hazards, avoiding 17
Height 42
High-pressure cleaners 71
Holder gas cylinder 35
Hygiene 18
Hygiene standard 18
- I**
Incorrect use 15
Inert gas 43, 125
Inert gas connection 31
Inert gas nozzle 30
Inert gas, connecting 53
Information labels 26
Inputs, sealing 63
Installation conditions 42
Installation location 17
Installation site 45
Instructed person 125
Instructions to follow 9
Intended use 14
Intensive cleaning, performing 82
Intermediate disinfection, performing 76
Internal vacuum pump 99
IT network 17
- K**
Key 32
- L**
Label 25
Language selection 59
- Load recipe 59
Load recipe quickly 59
Lock 36
Locking device, chamber lid 30
Login 58
Low pressure cleaning 74
Low pressure disinfection 75
Low-pressure test 19
- M**
Machine control 32
Machine cycles 126
Machine cycles, modifying 64
Machine cycles, resetting 64
Machine labels 25
Machine setup 45
Machine shutdown 111, 114
Machine storage 114
Machine, cleaning 74, 76
Machine, disinfecting 76
Machine, monitoring 16
Machine, switching off 54
Machine, switching on 54
Machine, transporting 111
Machine's hours of operation 65
Main switch 23, 24
Mains fuse 41
Mains fuse, max. 41
Mains voltage 41, 50
Maintenance recommendation 92
Manual cleaning 74
Manufacture of spare parts 12
MCV 40, 126
MCV duration 126
MCV threshold 126
Measurement of residual oxygen 19
Menu tree 39
MHP 40, 127
MHP evacuation pause 127
MHP evacuation time 127
MHP, setting 62
Misuse 14
Modifications 12
Monitoring obligation 16
MPP 40, 128
MPP, setting 62
MRP 40, 129
MRP, setting 63
- N**
Noise exposure 43

Nominal current 41
Nominal power 41
Nominal suction capacity 43
Non-ionising radiation 14
Number of cycles 129

O

Oil disposal 116
Oil level, checking 47
Oil sight glass 48, 98, 99
Oil, adding 48, 99
Oil, changing 98
Oil, draining 98
Oil, filling 47
Operating company, obligation 15
Operating directive, creating 15
Operating height 42
Operating hours 125
Operating materials 116
Operating pressure for sealing, setting 68
Optional equipment 34
Overview of levels 39

P

Pack, checking 19
Packaging process 40
Packing products 54
Parameters, setting 57
Parking brake 30
Password 58
Personal protective equipment 17
Personnel, training 16
Phases 41
Post evacuation time 130
Pouch clamp 34
Power supply 17, 31, 41
Power supply, connecting 50
Preset recipes 40
Pressure equipment, testing 20
Pressure regulators, setting 68
Process data 36
Process data status display 36
Process sequence 39
Production data 130
Program 59
Protection type 41
Protective equipment 17
Purging time gas flushing 130

Q

Quick disinfection 75

R

Rear view 31
Reasonably foreseeable incorrect use 14
Recipe 59, 130
Recipe keys 59
Recipe, deleting 60
Recipe, saving 60
Recipes 40
Relative air humidity 42
Requirements, gas supply 17
Reset machine control 66
Reset password 58
Residual current protective device 17
Residual risks 15

S

Safety devices 22, 25
Safety instructions 10
Safety labels 26
Scope of delivery 7, 45
Screw plug of drain opening 48, 98, 99
Screw plug of fill opening 48, 98, 99
Seal seam strength 19
Seal seam width 19
Sealing 63, 130
Sealing bar 30
Sealing bar, installing 105
Sealing bar, removing 104
Sealing bar, replacing 104
Sealing length 42
Sealing pressure 43
Sealing pressure regulator 68
Sealing pressure, setting 68
Sealing procedure, cancelling 33
Sealing time 130
Sealing time max 130
Sealing, operating pressure 43
Sealing, setting 63
Select process 61
Selection of personnel 16
Sensitive products 40
Set MCV 61
Set process 61
Set standard 61
Setting the suction speed 67
Setting up 45
Settings - Production data 130
Setup 68
Short-circuit current 41
Short-circuit current, max. 41
Show settings 65

Sloping insert, inserting 69
Sloping insert, removing 69
Software version 35
Spacer plate 130
Spare parts 119
Spare parts for pumps 121
Stacking test 19
Standard 131
Standard process 40
Startup display 35
Status display 36
Steam jets 71
Storage temperature 42
Storage test 19
Suction throttle 34
Supply lines, closing 111
Supply lines, disconnecting 111
Swivel castor 30
Symbols 8

T

Target group 10
Target values 130
Technical products 40
Technical specifications 41
Technician 131
Testing procedure 19
Third-party part 15
TN-S network 17

Total cycles 64, 131
Transport 111
Transport damage 45
Transport equipment 111
Troubleshooting 107
Type designation of machine control 35

V

Vacuum pump 21, 22, 43, 46, 112, 113, 114
Vacuum pump - production data 131
Vacuum pump hours of operation 65
Vacuum pump, external 50
Vacuum pump, running-on time 131
Vacuum test 131
Vacuum test, performing 103
Values, changing 57
Ventilate diaphragm 131
Ventilation 131
Ventilation pulse, pressure 132
Version number 54
Visual inspection 91, 92

W

Warnings 8
Weight 42
Width 42
Working equipment 116

MULTIVAC branch offices

GERMANY

MULTIVAC Sepp Haggenmüller GmbH & Co. KG
Tel.: +49 83 34 601 0
Fax: +49 83 34 601 199
multivac@multivac.de
www.multivac.com

SWITZERLAND

MULTIVAC EXPORT AG
Tel.: +41 41 785 65 65
Fax: +41 41 785 65 10
meag@multivac.ch
www.multivac.com

GERMANY

MULTIVAC Marking & Inspection GmbH & Co. KG
Tel.: +49 5224 931-0
Fax: +49 5224 931-299
multivac-mi@multivac.com
www.multivac.de

GERMANY

MULTIVAC Resale & Service GmbH
Tel.: +49 2157 8197 0
Fax: +49 2157 8197 22
info@multivacresale.de
www.multivac.de

ARGENTINA

MULTIVAC Argentina S.A.
Tel.: +54 11 4723 3766
Fax: +54 11 4723 4098
info@multivac.com.ar
www.multivac.com

AUSTRALIA

MULTIVAC Australia PTY. LTD.
Tel.: +61 3 8331 2800
Fax: +61 3 8331 2810
info@multivac.com.au
www.multivac.com

BELGIUM

Multivac N.V.
Tel.: +32 15 569 50 9
Fax: +32 15 569 50 1
mub@multivac.be
www.multivac.com

BRAZIL

MULTIVAC do Brasil
Tel.: +55 19 3795-0818
Fax:
nelson.dematos@br.multivac.com
www.multivac.com

BULGARIA

MULTIVAC Bulgaria EOOD
Tel.: +359 2 988-55-00
Fax: +359 2 988-55-88
service@bg.multivac.com
www.multivac.bg

CHILE

MULTIVAC CHILE S.A.
Tel.: +56 27 996 00 0
Fax: +56 27 996 00 1
mucl@cl.multivac.com
www.multivac.com

CHINA

MULTIVAC (Shanghai) Trading Co.
Building 7, Lane 195, Qianpu Road (Shanghai)
Tel.: +86 21 3701 8118
Fax: +86 21 3766 0051
info@cn.multivac.com
www.multivac.cn

DENMARK

MULTIVAC A/S
Tel.: +45 75 853 42 2
Fax: +45 75 853 45 4
mudk@multivac.dk
www.multivac.com

ESTONIA

MULTIVAC Oy Estonia Branch
Tel.: +372 622 8258
Fax: +372 622 8259
margus.kupp@ee.multivac.com
www.multivac.com

FINLAND

MULTIVAC Oy
Tel.: +358 20 792 13 00
Fax: +358 20 792 13 71
multivac@fi.multivac.com
www.multivac.com

FRANCE

MULTIVAC FRANCE S.A.S.
Tel.: +33 16 412 13 14
Fax: +33 16 412 75 30
muf@multivac.fr
www.multivac.com

GREECE

MULTIVAC Hellas Mepe
Tel.: +30 21 066 19 621
Tel.: +30 21 066 19 622
Fax: +30 21 066 19 662
info@gr.multivac.com
www.multivac.com

GREAT BRITAIN

MULTIVAC UK Ltd.
Tel.: +44 1793 425800
Fax: +44 1793 616219
sales@multivac.co.uk
www.multivac.com

INDIA

MULTIVAC Laraon India Private Limited
Tel.: +91 12 446 10 000
Fax:
info@multivac.co.in
www.multivac.com

IRELAND

MULTIVAC Ireland Ltd.
Tel.: +353 (0) 1 4133200
Fax: +353 (0) 1 4133205

www.multivac.com

ISRAEL

MULTIVAC B.P.S. Ltd.
Tel.: +972 46 344 68 1
Fax: +972 46 344 67 8
muil@multivac.co.il
il.multivac.com

ITALY

MULTIVAC Italia Service S.R.L.
Tel.: +39 02 450 32 08
Fax: +39 02 458 63 819
muit@it.multivac.com
www.multivac.com

JAPAN

Tokyo Foods Machinery Co. Ltd.
Tel.: +81 33 663 40 06
Fax: +81 33 662 49 41
t.orimi@tokyofoods.co.jp
www.multivac.com

CANADA

MULTIVAC Canada Inc.
Tel.: +1 905 264 1170
Fax: +1 905 264 9647
info@ca.multivac.com
www.multivac.com

COLUMBIA

Corporación MULTIVAC S.A.S. Oficinas
Tel.: +57 1 547 5241
Fax: +57 1 547 4276
info@co.multivac.com
www.multivac.com

CROATIA

MULTIVAC d.o.o.
Tel.: +385 14 855 20 5
Fax: +385 14 855 20 4
multivac@zg.t-com.hr
www.multivac.com

LATVIA

MULTIVAC Oy Latvia Branch
Tel.: +371 67 623 121
Fax: +371 67 622 602
girts.lazdins@lv.multivac.com
www.multivac.com

LITHUANIA

MULTIVAC Oy filialas Bukiškės
Tel.: +370 52 105 03 6
Fax: +370 52 336 41 3
donatas.margis@multivac.com
www.multivac.com

MEXICO

MULTIVAC Mexico S.A. de C.V.
Tel.: +52 55 502 05 555
Fax: +52 55 502 05 560
contacto@multivac.com
www.multivac.com

NEW ZEALAND

MULTIVAC New Zealand Ltd.
Tel.: +64 9 238-3055
Tel.: +64 2 146-0807
Fax: +64 9 238-3054
info@multivac.co.nz
www.multivac.com

NETHERLANDS

MULTIVAC BV
Tel.: (+31) 0348 436570
Fax: (+31) 0348 436580
munl@multivac.nl
www.multivac.com

NORTH AFRICA

MULTIVAC Afrique du Nord
Tel.: +216 71 963 963
Tel.: +216 71 860 128
Fax: +216 71 860 230
munaf@multivac.fr
www.multivac.com

NORWAY

MULTIVAC AS
Tel.: +47 33 445 25 0
Fax: +47 33 445 25 1
mun@multivac.no
www.multivac.com

AUSTRIA

MULTIVAC Vertriebsgesellschaft mbH
Tel.: +43 (0)1 698 1300
Fax:+43 (0)1 698 1300-99
info@multivac.at
www.multivac.com

ROMANIA

MULTIVAC Romania S.R.L
Tel.: +40 21 345 34 61
Fax:+40 21 345 34 61
adrian.dobre@multivac.ro
www.multivac.com

SERBIA

MULTIVAC d.o.o.
Tel.: +381 21 4721 144
Fax:+381 21 4721 146
info@multivac.rs
www.multivac.com

SPAIN

MULTIVAC Packaging Systems España, S.L.
E - 08396 Sant Cebrià de Vallalta (Barcelona)
Tel.: +34 902 290 909
Fax:+34 937 632 517
info@es.multivac.com
www.multivac.com

CZECH REPUBLIC

MULTIVAC Packing Machines, Ceska Republika S.R.O.
Tel.: +420 26 126 05 16
Fax:+420 26 126 05 18
mucz@cz.multivac.com
www.multivac.com

POLAND

MULTIVAC Sp. z o. o.
Tel.: +48 81 746 67 00
Fax:+48 81 746 67 01
mupl@multivac.pl
www.multivac.com

RUSSIA

MULTIVAC Rus / Moscow
127254 Moscow
Tel.: +7 495 604 4902
Fax:+7 495 604 4903
office@ru.multivac.com
www.multivac.com

SINGAPORE

MULTIVAC Pte. Ltd.
Tel.: +65 6565 3919
Fax:+65 6566 9798
David.Lum@sg.multivac.com
www.multivac.com

SOUTH AFRICA

MULTIVAC Southern Africa PTY. (LTD.)
Tel.: +27 16 340 5800
Fax:+27 16 340 5819
alex.ferguson@multivacsa.com
www.multivac.com

TURKEY

MULTIVAC Ambalaj Makineleri San. ve Tic. A.Ş.
Tel.: +90 216 526 00 33
Fax:+90 216 526 03 83
info@tr.multivac.com
www.multivac.com

PORTUGAL

Multi Vacuo - Sistemas de Embalagens Lda.
Tel.: +351 21 41 95 541
Tel.: +351 93 77 74 355
Fax:+351 21 41 95 543
diogo.magalhaes@pt.multivac.com
www.multivac.com

SWEDEN

MULTIVAC Sverige
Tel.: +46 311 70 0
Fax:+46 150 30 0
mus@multivac.se
www.multivac.com

SLOVAKIA

MULTIVAC Export AG organizačná zložka Slovakia Ges.m.b.H & Co. KG
Tel.: +421 24 446 40 70
Fax:+421 24 446 40 72
info@sk.multivac.com
www.multivac.com

SOUTH KOREA

MULTIVAC KOREA CO., LTD
Tel.: +82-70-4895-4041
Fax:+82-70-8244-4050
info@kr.multivac.com
www.multivac.com

UKRAINE

MULTIVAC Ukraine LLC
Tel.: +380 44 499 90 70
Fax:+380 44 499 90 67
office@ua.multivac.com
www.multivac.com

HUNGARY

MULTIVAC Hungária Kft.
Tel.: +36 23 500 28 7
Fax:+36 23 500 28 8
info@hu.multivac.com
www.multivac.com

USA

MULTIVAC, Inc.
Tel.: +800 877 5200
Tel.: +1 816 891 0555
Fax:+800 347 6164
Fax:+1 816 891 0622
muinc@multivac.com
www.multivac.com

UNITED ARAB EMIRATES

MULTIVAC Middle East (FZE),
Amir Sotoudeh
Tel.: +971 4 299 1980
Fax:+971 4 299 1981
amir.sotoudeh@ae.multivac.com
www.multivac.com